



PX-2200 SERIES Owner's Manual

PX-2208
PX-2208D
PX-2212D
PX-2216D

Fender[®]

ELECTRONICS

P/N047476

Introducing Fender Professional Sound Equipment, and the PX-2200 Series Professional Powered Mixing Consoles

Congratulations, and thank you for purchasing the Fender PX-2200 Series powered mixing console. We are sure that it will provide you with many years of trouble-free service.

At Fender, we know that artistry exists on multiple levels.

There is the individual musician (a guitar player, bass player, keyboardist, percussionist, or vocalist) who has dedicated years of practice to his or her craft, and puts their soul on the line every time they get up in front of an audience. And there are sound engineers and others in the technical performing arts, who are every bit as much a creative artist as the performers on stage.

We understand your needs because we are performing and technical artists ourselves. We are also skilled engineers in various disciplines, and fine craftsmen in materials and finishes. Like you, all of our people have dedicated their lives to their art, and have invested it in the product you have just purchased. Our art is to help you extract your art, allowing you the freedom to reach the level of your talent, and to help you provide it to your audience, thus enriching everyone's life.

That is what has made Fender the benchmark line of guitars, basses, and amplifiers throughout history, and what makes us different from many of our competitors today.

Obviously you know this, because you have just bought a Fender product. But allow us to let you in on a little secret. Because of this dedication, we have put a huge number of hours into creating a quality instrument (yes, because we believe that sound equipment is a creative instrument, just like a Strat, Tele, or Twin!). This instrument, the PX-2200, will come to life under your hands, and holds many secrets that you will discover as you use the product over time. Like nearly anything good in life, this will require practice and use.

If, however, you would like to take a short cut, achieve quick enlightenment, learn some of the secrets this little box has to offer, and how you can make use of that knowledge in your art now, take a few hours to read this owner's manual. While we cannot promise that you will discover all the secrets of the universe, it will help you to come up to speed on this product quickly.

In order to do this, the manual is broken down into easy to swallow segments. In writing this, we didn't set out to recreate "War and Peace" and wouldn't expect you to put aside a huge chunk of your life to hearing our words of wisdom. So please don't let the size of this manual have you looking for the oxygen masks and emergency exits!

After the table of contents, part 1 of the manual deals with setting up the PX-2200. Because of its unique integral road case/stand design, reading at least this section is an absolute **MUST!**

Part II of the manual quickly shows you an input channel, the output section, and the power amplifier module of your PX-2200, and points out the key features you will be using.

Part III shows how the PX-2200 is a complete sound system. This section contains detailed block diagrams of the entire system as well as each section, and includes an explanation of how to read block diagrams for beginning users.

Part IV is a self-teaching guide on how to use the PX-2200. If you are new to sound equipment of this complexity, this is a great way to gain much knowledge that you can use right away. It takes you through the knobs and switches one by one, and explains not only their operation, but also *artistic* ways you can use these controls. The exercises suggested in the self teaching guide allow you to actually try out each control, in a way that will show you the *reason* for using the control that way, and how it can help you in a performance. If you are an experienced user, you may wish to skip this section.

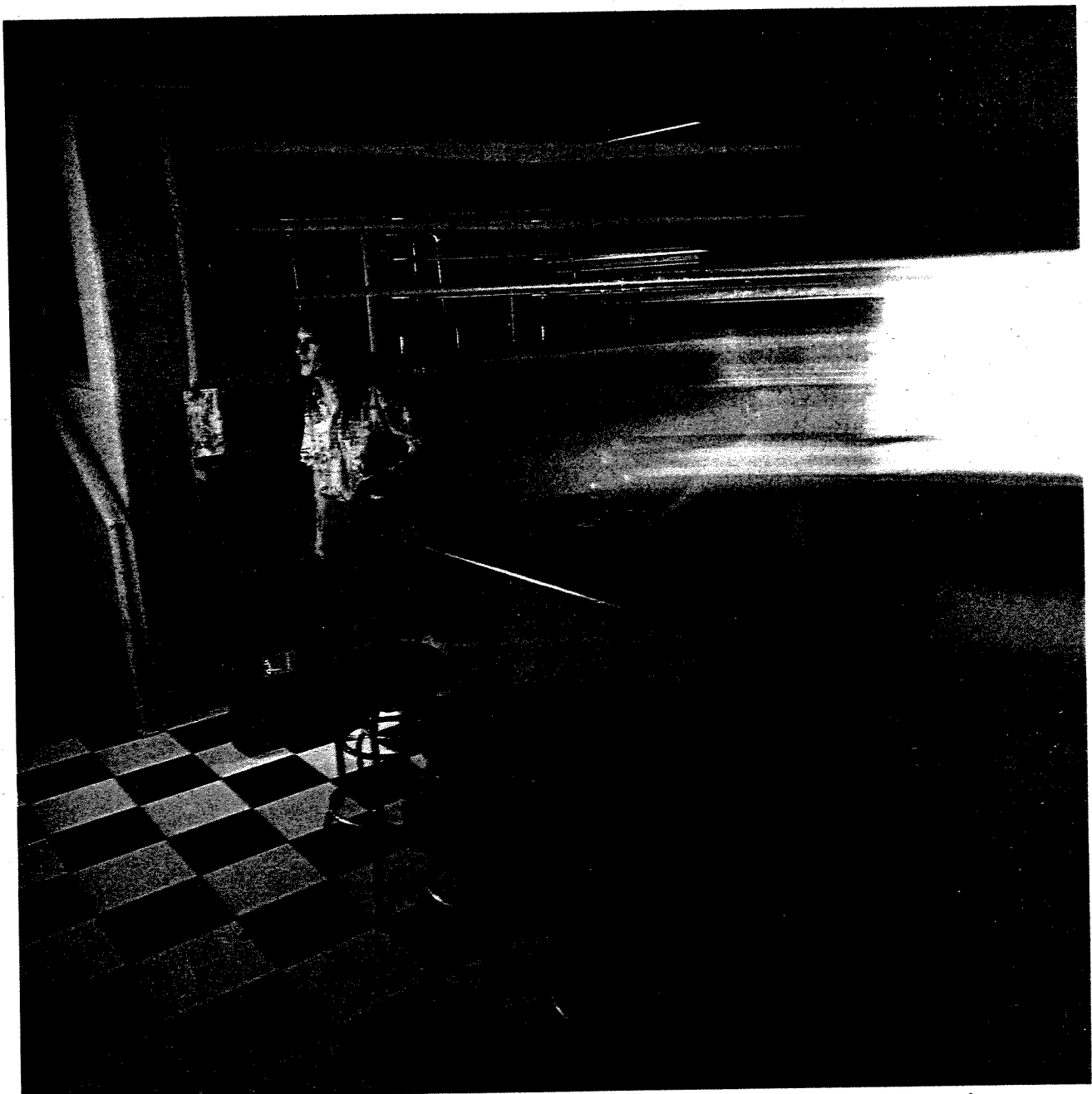

Part V is a crash course on cables, interconnects, and electrical safety when using sound equipment. Again, if you are new to sound equipment, reading this section is *highly* recommended.

Part VI deals with troubleshooting your sound system, and can be a valuable help when you don't know where to turn.

Part VII deals with microphones & loudspeakers, and has some valuable data on using them with your PX-2200. As the old saying

goes... "garbage in, garbage out". If you use poor quality transducers, even the best electronics (like your PX-2200) can't help much. You may avoid a lot of grief by reading this section.

Part VIII shows several example systems, and how you can use the PX-2200 with other equipment. These examples are not all inclusive however. Only your imagination will limit the number of different ways you can use the PX-2200.

Finally, Part IX is a reference section, with gain maps, specifications, and technical documents (schematics and component layouts), as well as your warranty statement.

So please, take some time to read at least the first part of this manual, as it contains important information about your PX-2200, including how to extract some of its really neat tricks.

Table Of Contents:

An Introduction	Pages 2 & 3
A. Table Of Contents	Pages 2 & 3
Part One: Unpacking, Setting Up, & Tearing Down The PX-2200 Console.	Pages 4 to 7
A. Unpacking The Mixer	Pages 8 to 11
B. The Quick Set Up	Page 8
C. Using the Stand/Table Set Up	Page 8
D. Tear Down	Pages 8 & 9
Part Two: PX-2200 Features	Page 10
A. Mixer Input Channel Features	Pages 12 & 13
B. Mixer Master Output Features	Page 12
C. Power Amplifier Features	Page 13
Part Three: PX-2200 System Block Diagrams	Page 12
A. What Is A Block Diagram	Pages 14 to 21
B. Systems & Components	Page 14
C. Understanding Block Diagrams	Page 14
D. Basic Sound System (Individual Components) Block Diagram	Page 17
E. Basic Sound System (PX-2200) Block Diagram	Page 17
F. PX-2200 Complete Block Diagram	Pages 18 & 19
G. An Exercise: Reading The Block Diagram	Page 20
H. Notes	Page 21
Part Four: A Self-Teaching Exercise: How to Use Your PX-2200 Console	Pages 22 to 58
A. The Artistry Of Mixing	Page 22
B. The Exercises	Page 22
1. The Site	Page 22
2. Differences Between Various Models Of The PX-2200	Page 22
3. Necessary Equipment	Page 23
C. The PX-2200 Mixer	Page 24
1. What Is A Mixer	Page 24
2. Inch By Inch & Row By Row	Page 24
3. You're Either On The Bus Or Off The Bus	Page 24
4. The Mixer Input Module	Page 25
A. Mic Inputs	Page 25
B. Line Inputs	Page 25
C. Mic Preamp	Page 25
D. The Trim Control	Page 26
E. The Peak Indicator	Page 26
F. Input Levels, Dynamic Range, & Headroom	Page 26
G. An Exercise	Page 27
1. The Initial Control Setup	Page 29
2. Turning It On	Page 29
3. Using The Peak LED	Page 29
4. Using The Trim Control	Page 29
H. Phantom Power For Condenser Microphones	Page 30
1. An Explanation Of Phantom Power	Page 30
2. Adapters & Phantom Power	Page 30
3. Auxiliary Equipment & Phantom Power	Page 30
I. Mixer Input Channel Equalization (Tone Controls)	Page 30

1. What The Input EQ Controls Do	Page 32
2. Center Frequency	Page 32
3. Bandwidth	Page 32
4. Amplitude	Page 32
5. Types Of EQ.....	Page 32
6. Shelving EQ.	Page 32
7. Peak/Dip EQ.	Page 32
8. The PX-2200 Input Channel Equalizers	Page 32
9. An Exercise: Using The Input Equalizers	Page 33
10. Input EQ & Mixed Instruments	Page 35
11. A Precaution About Over-using Input EQ.	Page 35
J. The Insertion Point	Page 35
K. The Input Channel Faders	Page 36
1. An Exercise: Using The Faders	Page 36
2. Establishing A Balance	Page 37
L. What Is A Mix Bus?	Page 37
M. The Pan Control	Page 37
1. How A Pan Pot Works	Page 38
2. Operating The Pan Control	Page 38
3. An Exercise: Using The Pan Control	Page 38
N. Solo	Page 39
1. PFL Solo	Page 39
2. AFL Solo	Page 39
O. Auxiliary Sends.....	Page 39
1. Pre-Fader Sends	Page 40
2. Post Fader Sends	Page 40
3. An Exercise: Using The Monitors.	Page 40
A. Some Helpful Tips On Stage Monitors	Page 42
B. The Purpose Of Stage Monitors	Page 42
C. Types Of Stage Monitors	Page 43
1. Floor Wedge Monitors	Page 43
2. Side Fill Cabinets	Page 43
3. Overhead Fills	Page 43
4. Headphone Monitors	Page 43
D. Why Use A Pre-Fade Monitor Send	Page 43
E. An Acronym: K.I.S.S.	Page 44
F. Using The PX-2200 As A Monitor Mixer	Page 44
P. The Effects/Reverb System Of The PX-2200	Page 45
1. The Effects Mix Controls	Page 45
A. What The Effects Mix Does	Page 45
B. The Effects Mix Mater Section.....	Page 45
C. The Effects Section Patch Bay	Page 45
D. The Built-In Reverb/Effects Section	Page 45
E. The Effects Return Section.....	Page 48
F. An Exercise: Using The DSP Reverb	Page 48
G. Using The Effects Send With An Outboard DSP Processor	Page 49
Q. The Aux. Send.....	Page 49
R. Using True Stereo Effects Sends & Returns	Page 49
5. The Output Section	Page 49
A. The Return Of The Magic Bus	Page 50
B. The Summing Amplifier.....	Page 50
C. The Master Level Controls	Page 50
D. Line Amplifiers	Page 50
E. The Master Outputs	
1. The Left & Right Main Output	Page 50
2. The Mono Sum Output	Page 50

3. Submasters	Page 50
4. Auxilliary Send(s) Masters	Page 51
F. Monitoring & Metering	Page 51
1. VU Meters	Page 51
2. The Nominal Position	Page 51
3. Using V.U. Meters	Page 53
4. An Exercise: Using The VU Meters	Page 53
G. The Two Switchable Master Graphic Equalizers	Page 54
1. An Introduction To The Master Graphic EQ's	Page 54
2. An Exercise: Using The Master Graphic EQ's	Page 54
H. Headphones	Page 55
I. The Solo Level Control	Page 56
J. The Tape In Level Control & Tape Playback Jacks	Page 56
K. The Tape Out Level Control & Tape Record Out Jacks	Page 56
6. Power Amplifiers	Page 56
A. Amplifier Basics	Page 56
B. Dual Channel Power Amplifiers	Page 56
C. Amplifiers & Loudspeakers	Page 57
D. Impedance Concerns	Page 57
E. Converting Amplifier Power To SPL	Page 57
F. Series Impedance Calculations	Page 57
G. Parallel Impedance Calculations	Page 57
H. Series/Parallel Impedance Calculations	Page 58
I. Impedance & Power Transfer	Page 58
Part Five: Cables, Interconnects, Microphones, Speakers, & Electrical Safety	Pages 58 to 71
1. Understanding Balanced & Unbalanced Lines	Page 58
2. Connectors & Cabling	Page 59
A. Some General Notes On Cable	Page 59
B. Some General Notes On Connectors	Page 59
1. XLR Connectors	Page 59
2. 1/4" Phone Plugs	Page 59
3. RCA Type Phono Plugs	Page 60
C. Cable & Connectors For Microphones & Low Level Devices	Page 60
D. Microphone & Snake Cables	Page 64
E. Cables & Connectors For Line Level Devices	Page 64
F. Cables & Connectors For Loudspeakers	Page 64
G. Adapters	Page 65
H. Attenuator Pads	Page 65
I. Transformers	Page 65
3. The Electrical Representation Of Sound	Page 61
A. Signal Voltage/Amplitude	Page 61
B. Properties Of Electricity	Page 61
1. Voltage = Pressure	Page 61
2. Current	Page 61
A. Direct Current	Page 62
B. Alternating Current	Page 62
C. What Do We Mean By Phasing & Polarity	Page 62
1. An Exercise: Help Me, I'm Phasing	Page 62
2. An Exercise: Polarity & Phasing	Page 63
4. Grounding, Shielding, & Electrical Safety	Page 66
A. Warning!	Page 66
B. Grounding For Safety	Page 67
C. Grounding To Reduce External Noise Pickup	Page 67
H. Using Proper Shielding To Reduce Noise Pickup	Page 67
I. Reducing Noise Pickup From AC Lines	Page 67
J. Finding The Source Of A Noise Problem	Page 68
K. More Tips On Reducing Noise Pickup	Page 68

Part 6: Troubleshooting (Dealing With Feedback, Hum, Hiss, & Other Noises)	Page 68 to 71
A. Feedback	Page 68
B. Acoustic Solutions To Feedback	Page 69
C. Hum & Buzzes	Page 69
D. Hiss	Page 69
E. Other Noises	Page 70
F. Trouble Shooting A Sound System	Page 70
1. Know Your Block Diagram	Page 70
2. Know What Each Component Is Supposed To Do	Page 70
3. Know Common Trouble Spots	Page 70
4. Logical Troubleshooting	Page 70
Part 7: Microphones, Speakers, Etc.	Page 71
A. Types Of Microphones	Page 71
B. Choosing Microphones	Page 72
C. Using Direct Boxes & Other Pickups	Page 72
D. Other Sources	Page 73
E. Using Special Effects Devices	Page 73
1. Using Compressors, Limiters, Noise Gates, & Expanders	Page 73
2. Equalization	Page 74
A. Using Equalizers	Page 74
B. (So Called) Room Equalization	Page 75
C. Equalizers & Loudspeakers	Page 75
F. Choosing & Using Loudspeakers	Page 75
1. Types Of Loudspeakers	Page 75
2. Two Way, Three Way, And So On	Page 76
3. Woofers & Tweeters	Page 76
4. Choosing Loudspeakers	Page 77
5. Using Loudspeakers	Page 78
Part 8: Example Systems	Pages 80 to 85
A. Example One: A Small Mono P.A. System	Page 80
B. Example Two: A Small Mono P.A. System With Stage Monitors & A Stereo Recording Mix	Page 81
C. Example Three: A Small Stereo P.A. System, With An External Stage Monitor System & A Stereo Recording Mix	Page 82
D. A Large Stereo Tri-Amped P.A. System With External Amplifier Racks & Speaker Stacks, & 2 Stage Monitor Mixes	Page 83
E. Example Five: An 8-Track Home Project Studio, Using The Channel Insert Points As Direct Outputs	Page 84
F. Example Six: Using The PX-2200 As An On-Stage Monitor Mixing Console With A Separate Front Of House Console	Page 85

Setting Up The PX-2200 Powered Mixing Console

We're not going to start out by underestimating your intelligence right off the bat. Were all big kids, and all know how to open a box and pull out a unit, right? (If not, this manual WON'T be able to help you.)

By now you have probably taken the unit out of the shipping carton (how else would you be reading this manual?), and have at least lifted the "hood" to see what is inside that big black rectangle. That's OK, feel free, you bought it.

Now, lets do more than look-lets get to work.

QUICK SET UP, NOT USING THE BUILT-IN STAND.

All right, here's the scenario. You arrive at the gig a half hour late, due to a snowstorm, car breakdown, spouse, parents, children, whatever. Forget the sound check, the room is packed with people checking their watches and scowling at you. How do you get up and running quickly? While your bandmates bring in the other gear, you get to work setting up the p.a.!

Simply find the nearest table, and set the PX-2200 down on it (preferably with the lid (cover) face up, and located near some source of clean AC power). If the band is mixing, this will probably be on stage. If the soundman is mixing, any unpopulated table close to a wall outlet, and where you can hear the band well will suffice! Remove the cover from the PX-2200 road case, and set it on the side.

Put your house p.a. speakers (preferably on stands), and stage monitor speakers where you want them, run your speaker cables to the PX-2200 series and plug them in. Run your snake or mic cables up to the stage, and plug the inputs into the PX-2200 input connectors. Put the mics on the stands, plug them into the snake, plug in the AC power, flip the switch, and you're ready for prime time. By now you have probably figured out how easy it is to set up the PX-2200, and get up and going quickly.

THE "CHECK THIS OUT SETUP", USING THE BUILT-IN STAND.

Second scenario. You get to the gig in plenty of time to set up, and hopefully to even sound check. Figure out where you want to set up the PX-2200, and locate your source of AC power. If you have a PX-2208 or PX-2208D, this can probably be performed by one person. If you have a PX-2212D or PX-2216D, you may require the assistance of another person to help set up the mixer (at least in step 4). Now, follow the steps outlined below, and watch what happens:

1. Set the PX-2200 down on it's end, standing up, with the cover latch on the top (see example 1).
2. Unlatch the lid, pull it back and then off (examples 1 & 2). Set the lid close to you, so it can be put back into the unit to form part of the stand.

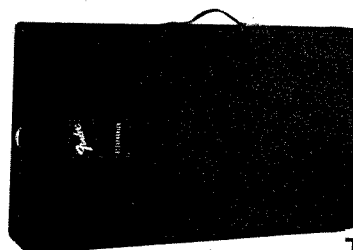

The
PX-2200 Folded Up
In Its Roadcase



Example One:
Unlatching The Lid



**Example Two:
Removing The Lid**

- Grab the black handle, at the top of the mixing console (near the center of the case), and slowly pull it up and towards you. The mixer should freely rotate on its pivot point. (Example 4) You should now be able to see the two black metal guide slots in the inside center of both side panels.

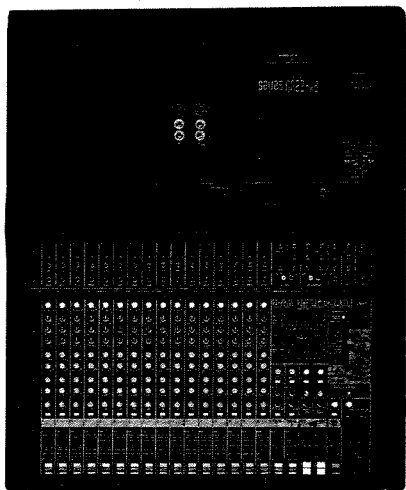

**Example Three:
Quick Set Up, Not Using The
Built In Stand**

- Take the lid you removed in step 2, and put the bottom of it into the two black metal guide slots located in the side panels of the mixer (Examples 5, 6, and 7). Be sure the two silver "quick-release" spring loaded latches are on the top side of the cover, where you can get to them. Now, push the lid down into the guides, as far as it will go (Example 8). It will stop in exactly the right position. When finished, the "quick-release" latch pins should be lined up with two small holes in the black metal guide slots (Example 9).

- Rotate the knurled handle on the "quick release" spring loaded latch, and the latch should pop into the hole in the guide slot (Example 10), thus securing the "X-shaped" stand assembly, comprised of the PX-2200 road case and the cover.
- Set the unit down on the floor. It should now stand on its own (Example 11).
- Now, slowly lower the mixer panel until it rests on the top of the carpet covered lid (Example 12 and 13).

It's that simple. Now you have a stand to hold the mixer at hand height while playing (if the band is mixing themselves on stage), or a desk that the sound engineer can sit at (holding the mixer at desk height for ease of operation and providing plenty of leg room for the sound engineer).

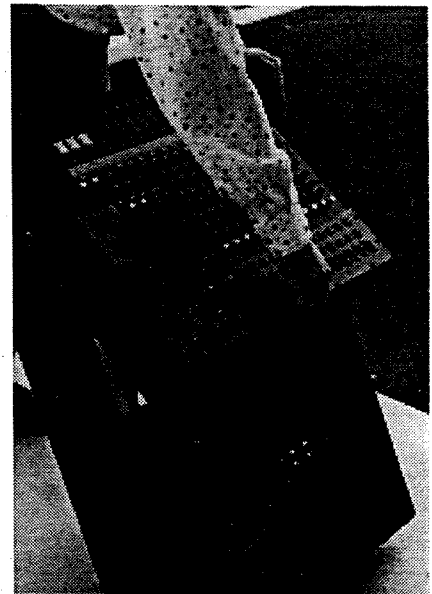

**Example Four:
Lifting The Mixer Panel.**

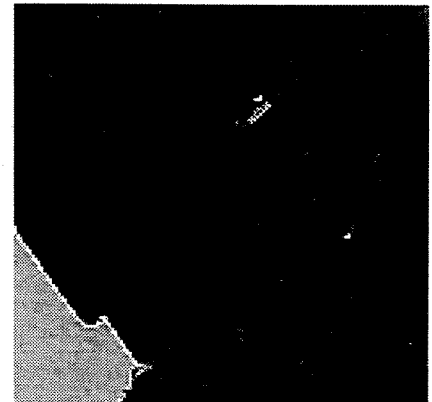

**Example Five:
The Metal Lid Guide Slots.**

**Example Six:
Inserting The Lid Into The
Metal Lid Guide Slots.**

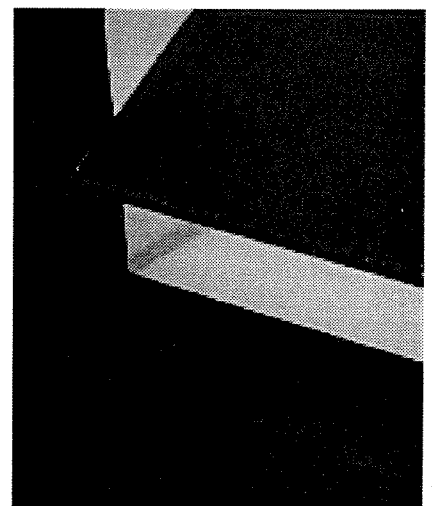



**Example Seven:
Sliding The Lid
Through The Slots.**



**Example 8:
Pushing The Lid
Through The Guide Slots**

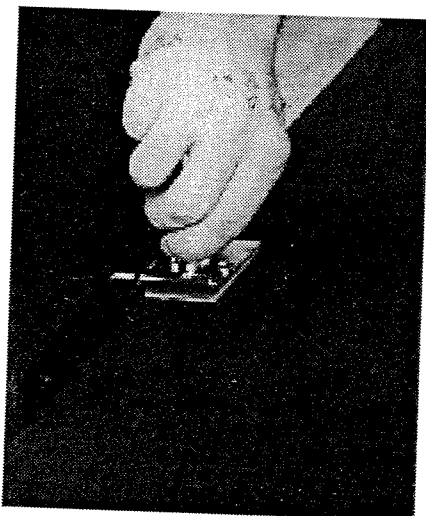

**Example Ten:
Flipping The Latches.**

Tear Down.

To disassemble the unit, pack it up, and head home, follow the steps outlined below:

1. Unplug all audio connectors from the PX-2200, and unplug the unit from the wall.
2. Carefully lift the mixer panel up by the black metal handle near the top of the mixer.
3. While holding the mixer up, reach in to where the two "quick-release" spring loaded latches are located, and pull back on the handle, rotating them (thus freeing the pin from the side panel), and locking it in place.
4. Keep holding the mixer up with one hand, and with the other hand pull the cover panel up and out of the mixer, and set it on the side.
5. Lower the mixer panel down, until it rests even with the side panels.
6. Grab the cover panel, and carefully set the bottom edge inside the two metal lid guides inside lower part of the road case (near the power amplifier module).
7. Close the lid into the case, secure the latch, and hit the road. The unit is now secure for transport.

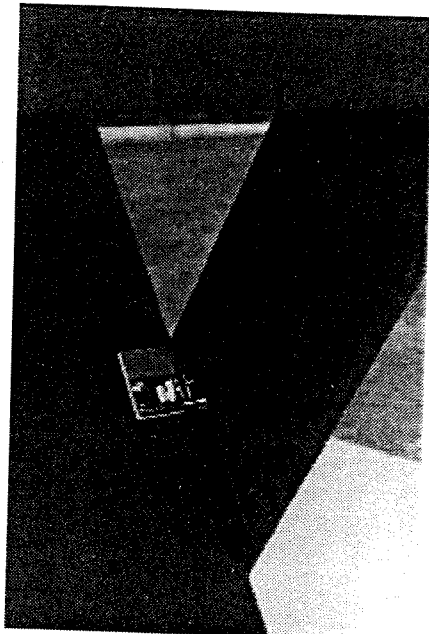

**Example 9:
Lid In Position For Latching**

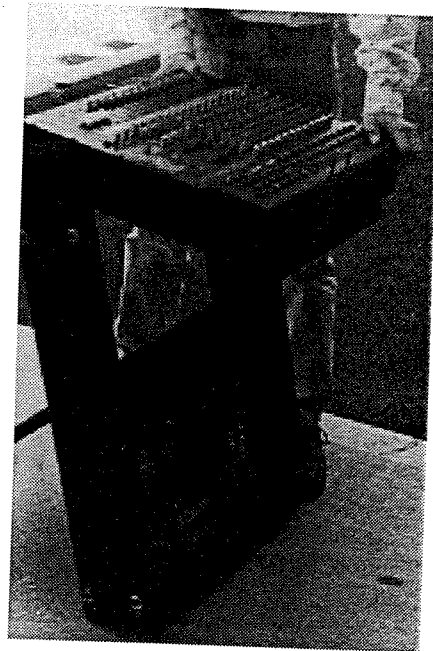

**Example 11:
Setting The Stand
Assembly On The Ground.**

**Example 12 (Following
Page):
Setting The Mixer Down.**

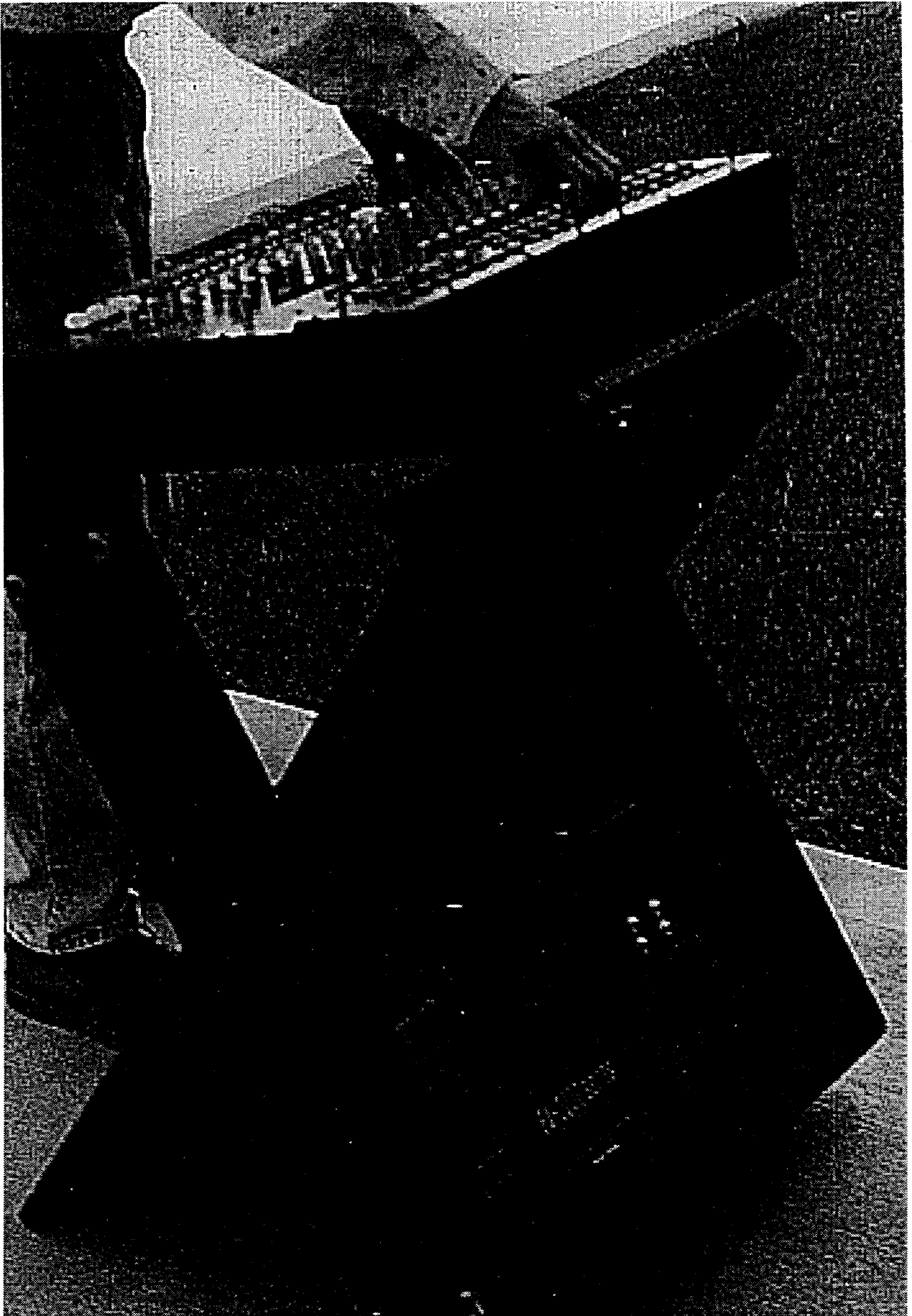

PX-2200 Series Power Amplifier Module Features

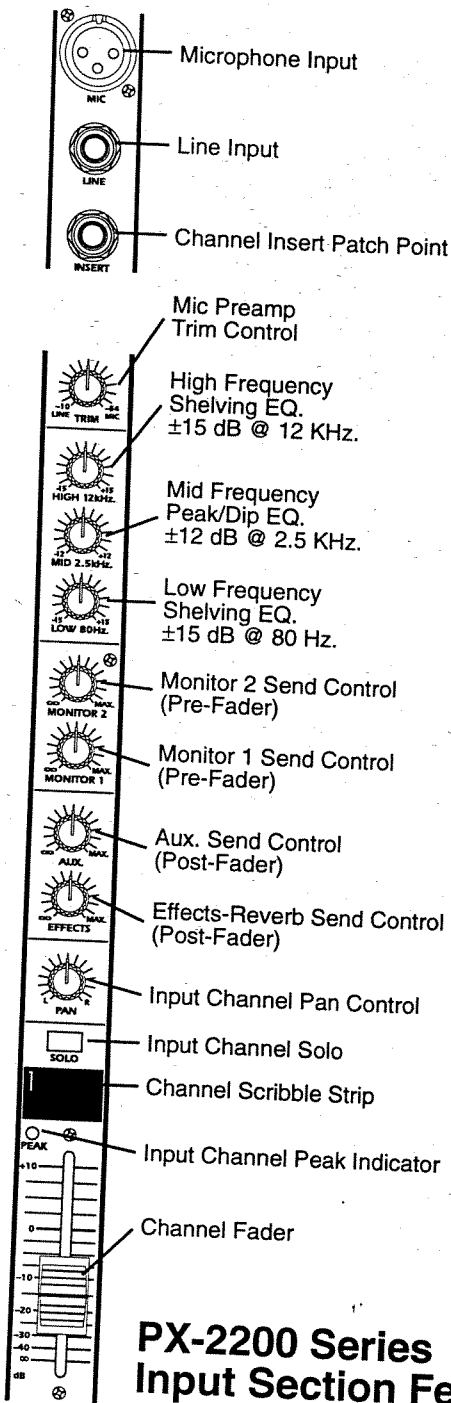
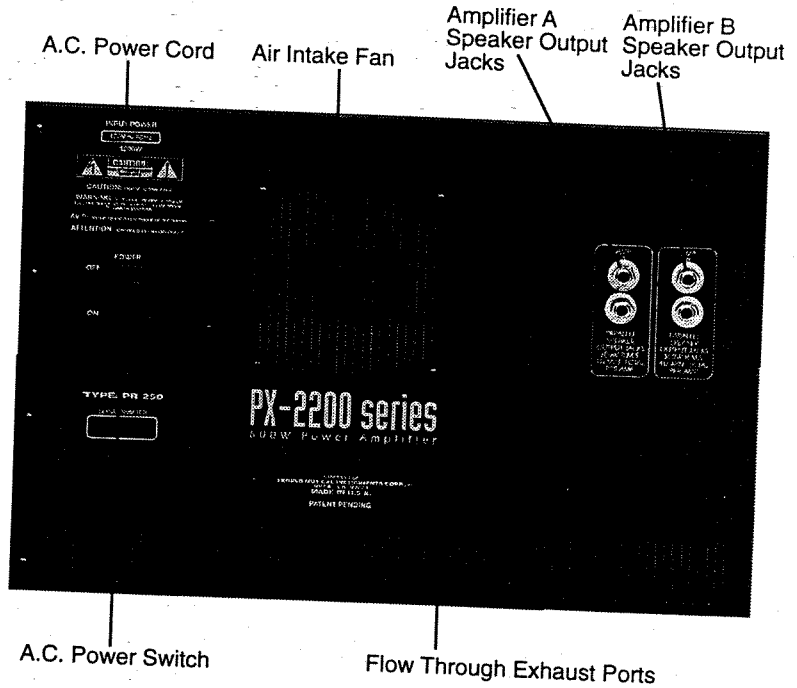

PX-2200 Series Input Section Features

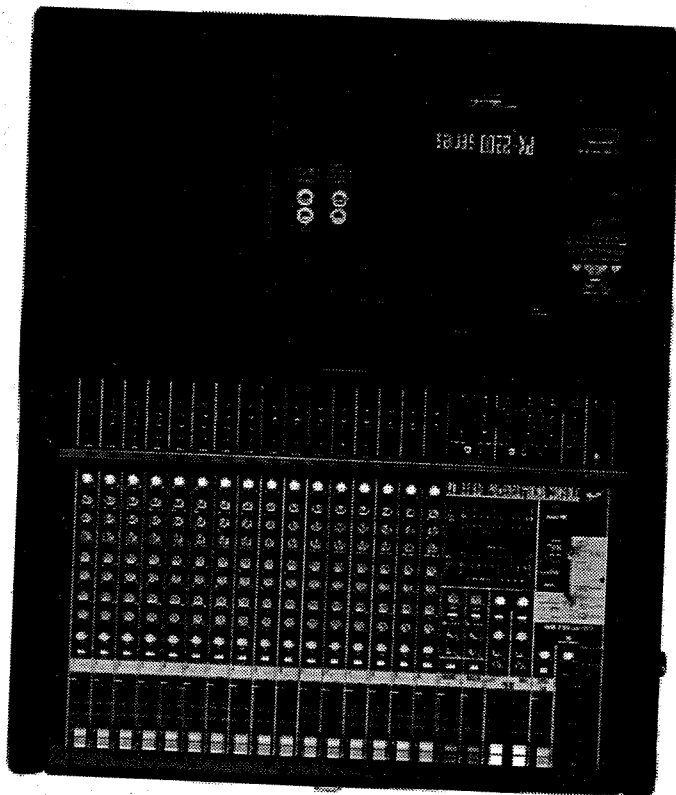

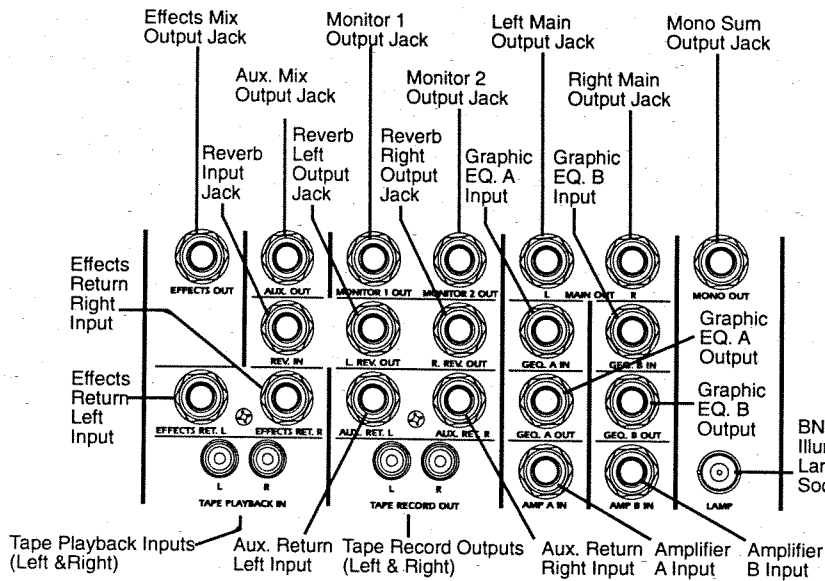

PX-2200 Series Output Section Features

BNC Illumination Lamp Socket

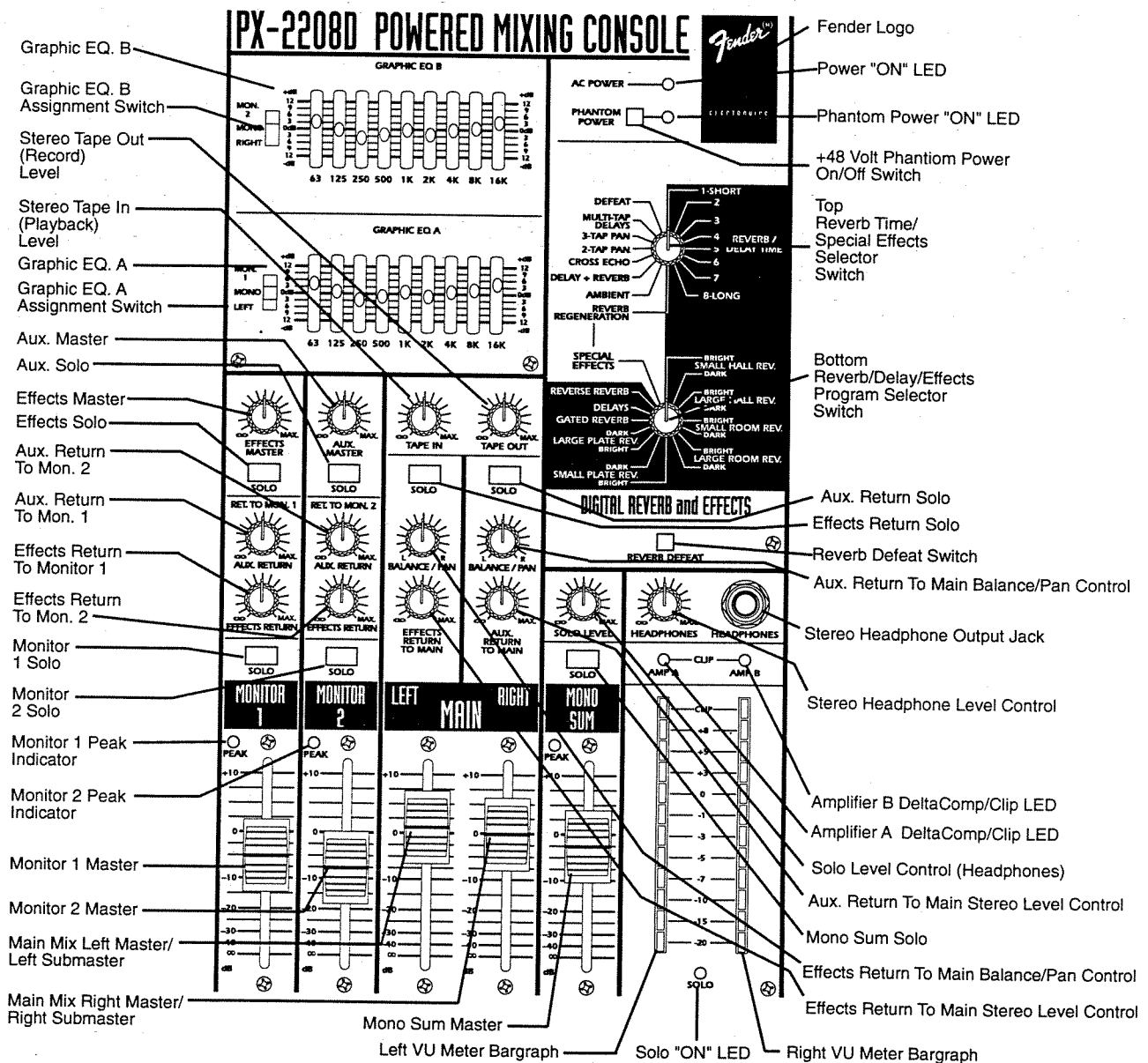

Reading and Understanding Block Diagrams

What Is A Block Diagram?

If you want to get from Tucson to Tucumcabee (or Tehachapi to Tonopah) you're most likely going to need a map. With sound equipment (especially in the complex configurations of contemporary sound reinforcement), a map isn't a bad idea either. A block diagram serves as a map. The map can show you the way through an entire sound system (more like a national map), or through a specific piece of audio equipment (somewhat akin to a city map).

If you aren't used to it, a block diagram may look remarkably similar to another form of technical diagram: the schematic. Schematic diagrams detail the component circuitry of a unit and can quickly become difficult to follow. Schematics are of primary use to technicians and repair people. The schematic diagram of your Fender PX-2200 Mixer (found in the reference section) shows every integrated circuit, every resistor, every connection. Although at some point you may need this information, it can actually get in the way of an understanding of the operation of the Mixer from the user's point of view.

For block diagrams, on the other hand, the key is simplicity. Utilizing a set of very simple symbols and a whole lot of labeled boxes, block diagrams can be very helpful to the end user, by providing an easy way of understanding just what's going on inside the equipment without requiring a degree in electrical engineering.

A block diagram removes all the unnecessary detail from the schematic and leaves only that necessary to understand the way the Mixer operates.

By learning how to read a block diagram, the user can have a reference point that helps explain how signals are routed inside the PX-2200, and why a control works the way that it does. If you do not know how to read a block diagram, we recommend that you carefully study the next section. That will explain not only how to read a block diagram, but it will tie the diagram to the real inputs, control knobs, features, and operation of your PX-2200. We'll get back to block diagrams in a second, but for now, let's take a look at just what is inside your PX-2200 series powered mixer.

Systems & Components.

In the past, and in many larger sound systems, the system was built of many independent pieces of equipment, all interconnected into a (hopefully) cohesive sound system.

In any sound system, there are two basic types of components: transducers and signal processors. That's it.

Like missionaries, the job of transducers is to convert. In the case of microphones, converting sound waves into electrical waves, and in the case of loudspeakers, converting electrical waves back into sound waves. The job of signal processors is to do something with that audio signal in between its transduction points.

A complete sound system would be comprised of transducers (such as microphones and speakers), and signal processors. Signal processors would consist of; mixers (a big box consisting of multiple pre-amplifiers, equalizers, level controls, mix amps, and line-level amplifiers, all intended to allow the operator to control the blend or "mix" of individual instruments or sounds), graphic equalizers (for controlling feedback and "shaping" the tone of a sound system), power amplifiers (to drive loudspeakers), and crossovers (for splitting low and high frequencies within a speaker system). Processors would also include special effects devices, such as compressors, limiters, and even a reverberation and other time delay devices!

In a very real way, your Fender PX-2200 Mixer is an entire sound system, all in one easy to transport box.

Internally, it is made up of input connectors, microphone phantom power supplies, pre-amplifiers, line-level amplifiers, equalizers, mix amps, graphic equalizers, compressor/limiters, power amplifiers, delay lines, and even an advanced digital reverberation and special effects unit! In order to understand how all of these entities are hooked together, and how a signal gets from the mic to the speakers, and what controls affect it along the way, we need our road map: the block diagram.

Understanding Block Diagrams.

Here are a few examples of the kind of symbols one would find in a block diagram:

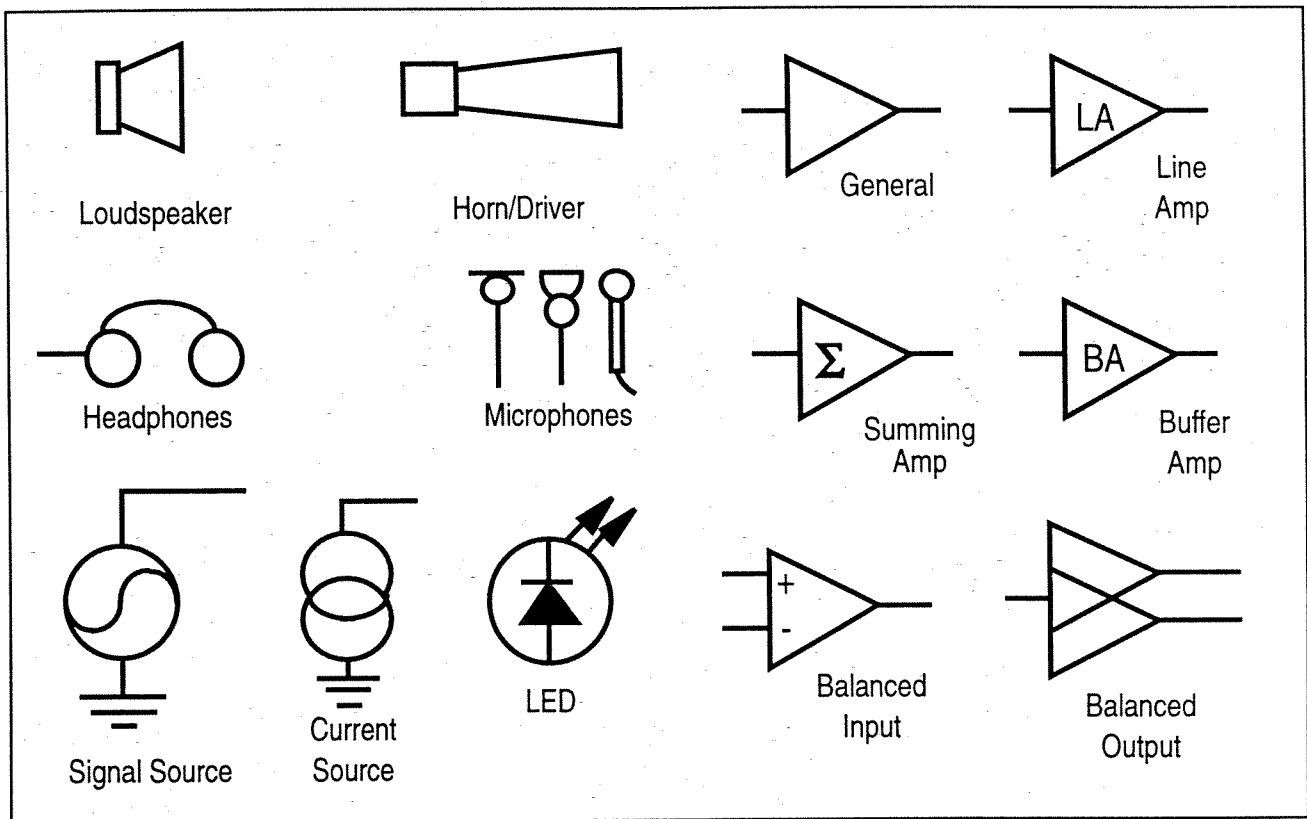

Now, let's put these symbols to use. The first example, shown on the top of page 17, illustrates a basic sound system block diagram.

While not as "busy" as other block diagrams we will look at later, this "systems" block diagram shows you how the individual components are ordered to create a basic sound system. This will be our equivalent of a "National" map. This block diagram is made up primarily of boxes and other symbols, which leads us to one of the basic rules to understanding a block diagram: **When in doubt about a block diagram symbol, draw a box, label it, and show the inputs and outputs to it!**

At this level, if we were to make up a block diagram of a sound system using your PX-2200 mixer, it would look like the second block diagram, found on the bottom of page 17.

Unfortunately, that is not very clear. To understand what is really going on, we need to know what is happening inside the PX-2200. This would be akin to a "State" Map, showing us how to get around inside the "state", and would look like the illustration on the top of page 18 and 19.

Thus, inside the PX-2200, the block diagram of your Mixer looks a lot like the block diagrams of a complete sound system, sans the transducers!

In order to better understand the PX-2200, we will break it down into the major components: the mixer, the graphic equalizers, the DSP reverb/special effects section, and the power amplifiers. For example, let's take a look at the mixer section of the PX-2200, which can be found on pages 18 and 19.

As you can now see, what was once only a simple rectangle or square with a name inside of it, is made up of a number of controls, amplifiers, connectors, etc.. This is like looking at a "City" map, it shows you how to get around inside this section.

Each major subsystem of your PX-2200 can be broken down in this way. The key to understanding HOW a signal travels through your PX-2200, is to trace the flow of a signal from the input, through to the output, tying the block diagram symbol to the actual controls and circuit sub-blocks inside the PX-2200. Again, the block diagram is your road map. Use it, or be condemned to wander in the wilderness of ignorance!

Now, let's get into the PX-2200, starting at the most logical beginning place: the mixing console subsection, and the place it all begins: the inputs.

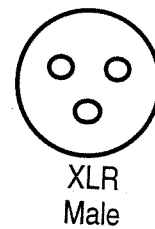
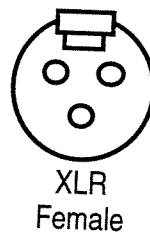
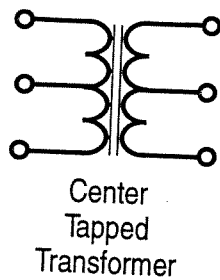
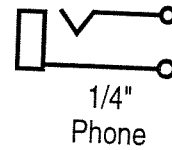
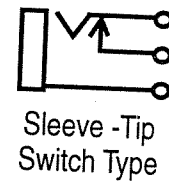
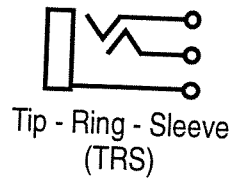
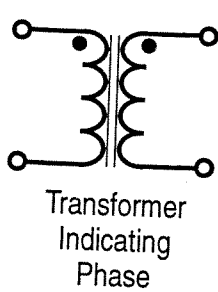
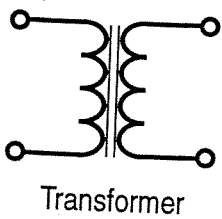
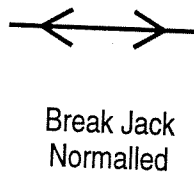
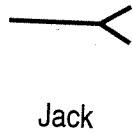
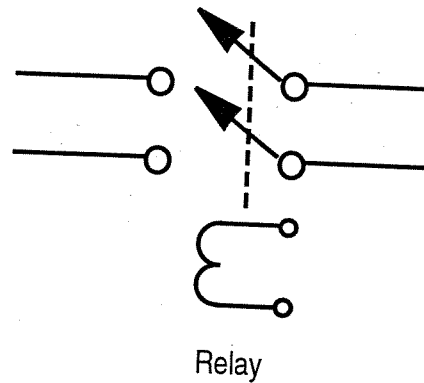
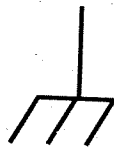
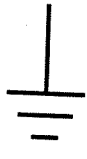
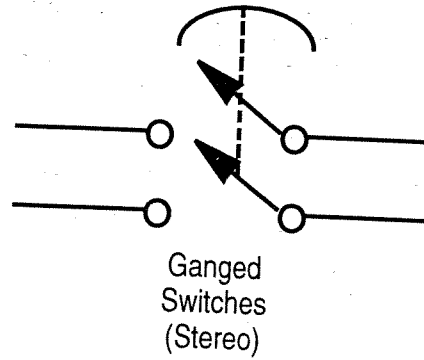
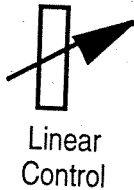
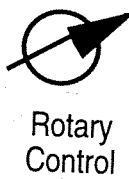
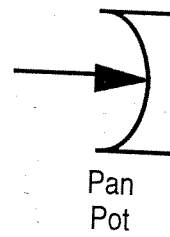
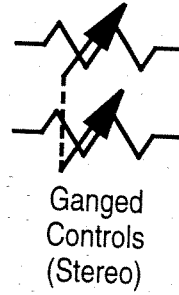
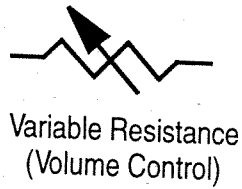
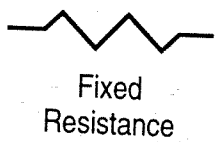

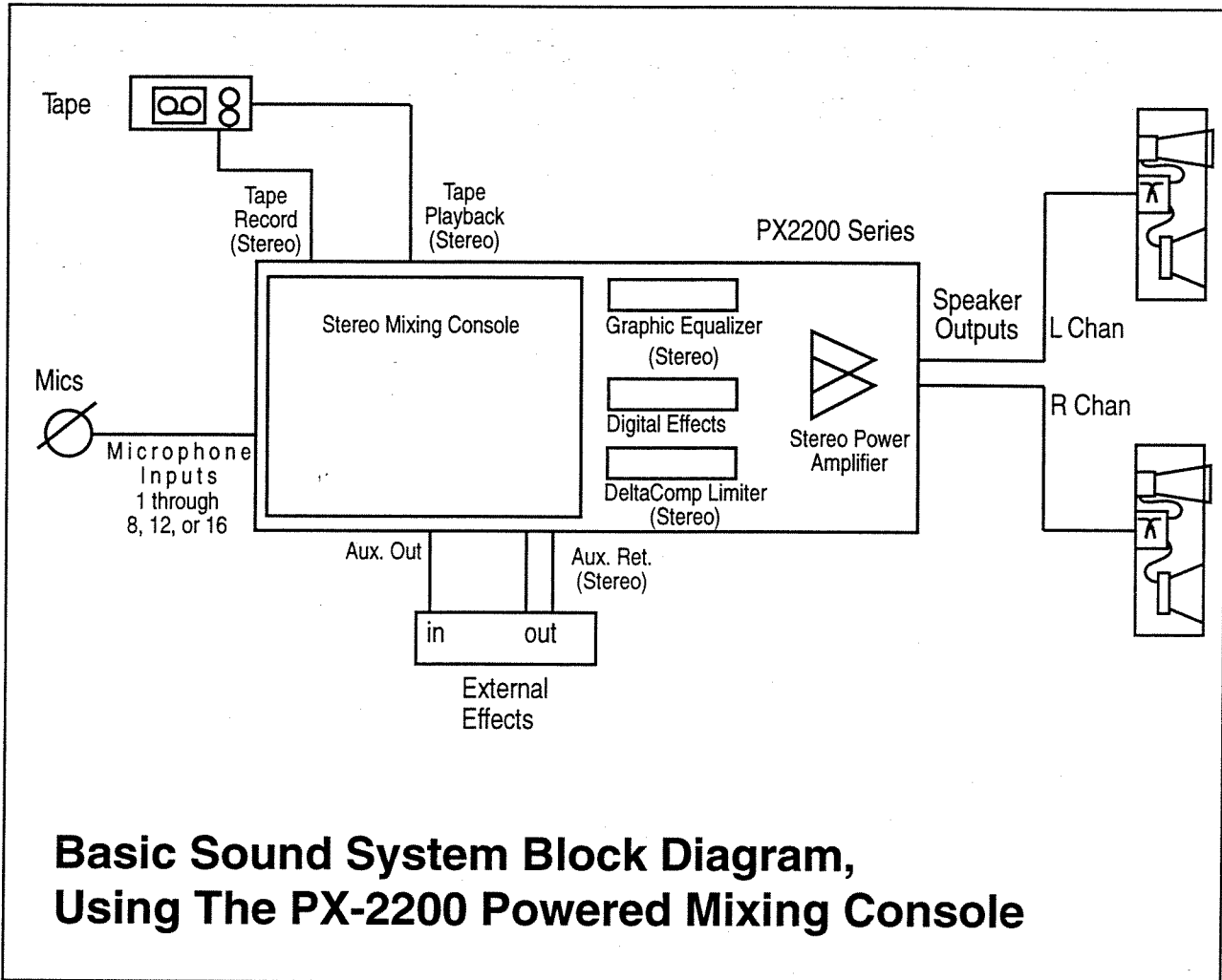
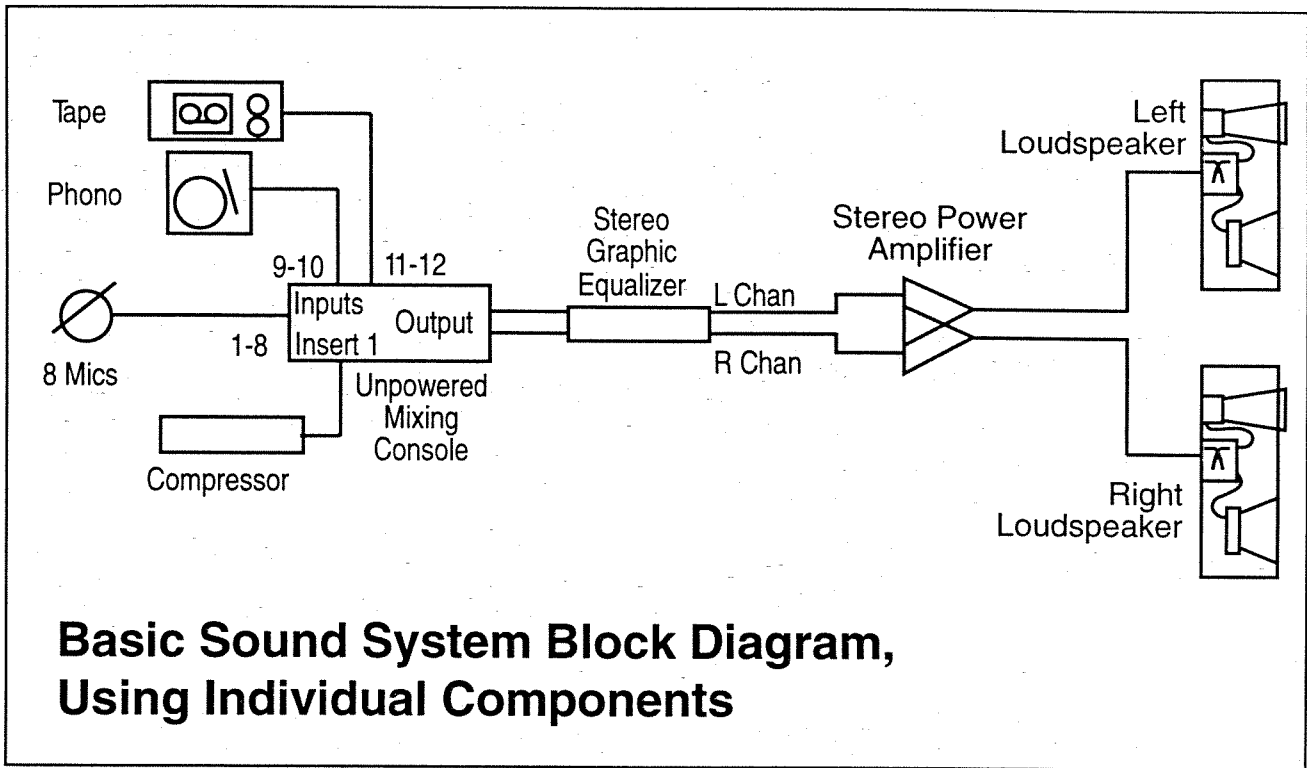

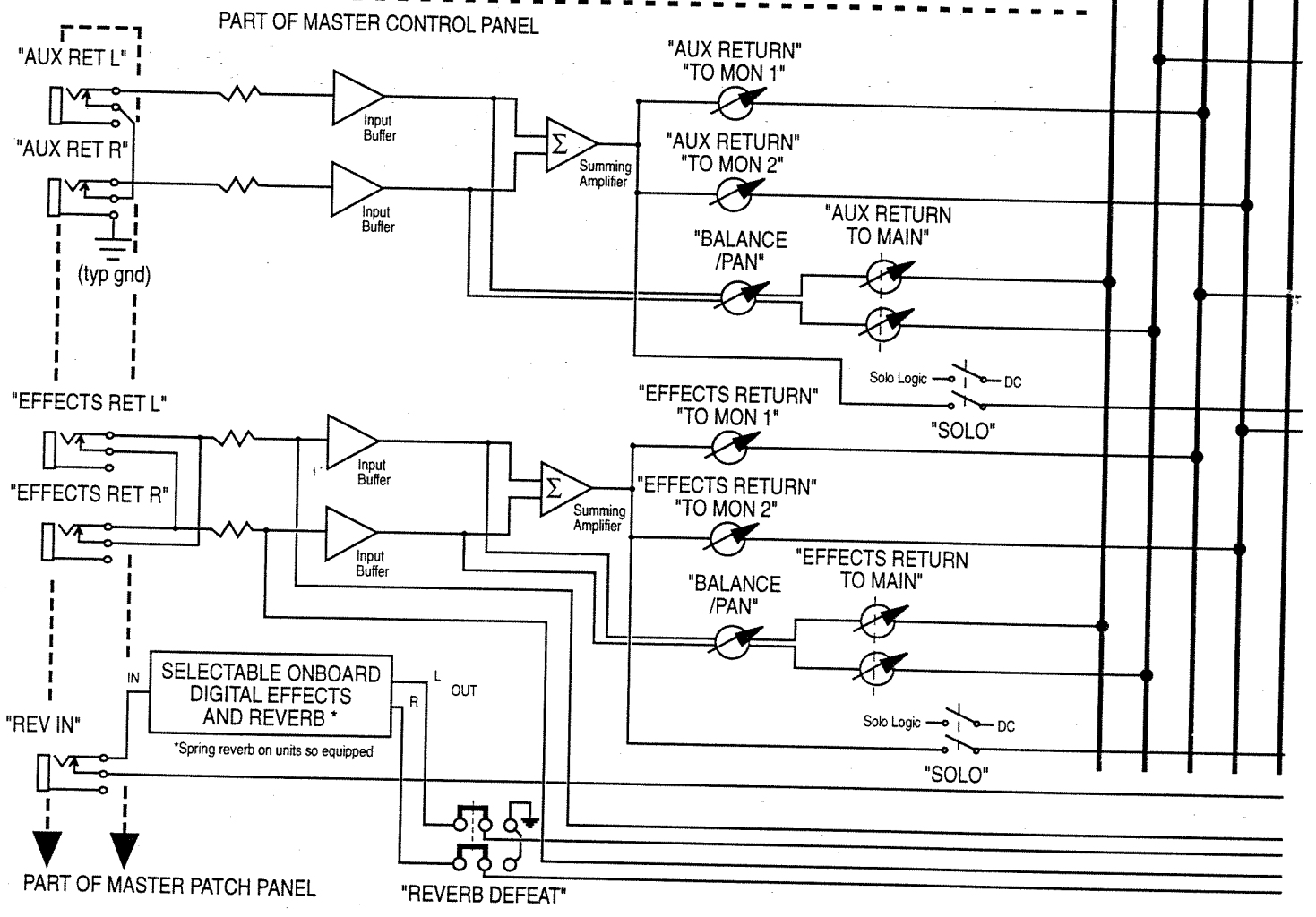
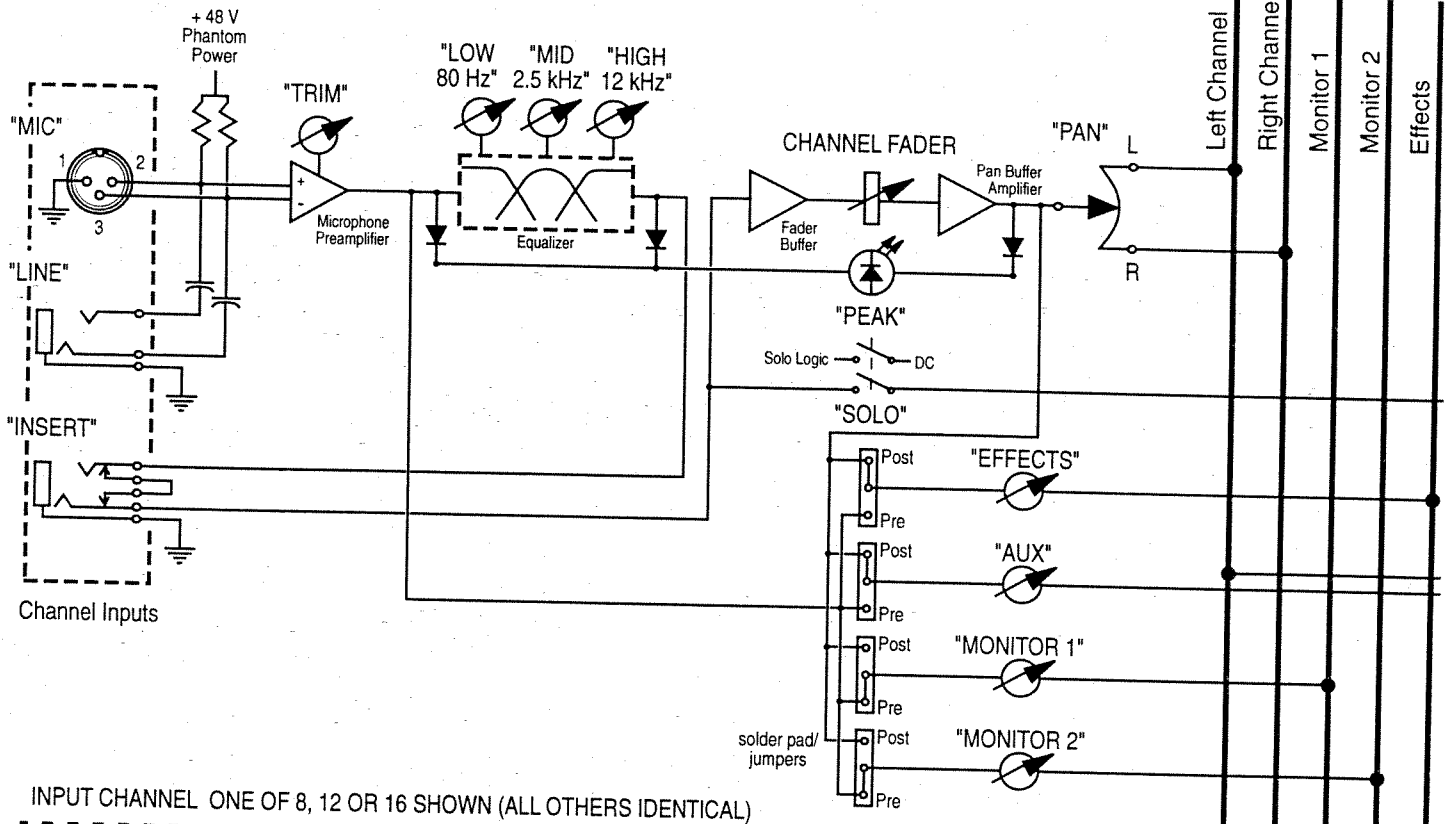

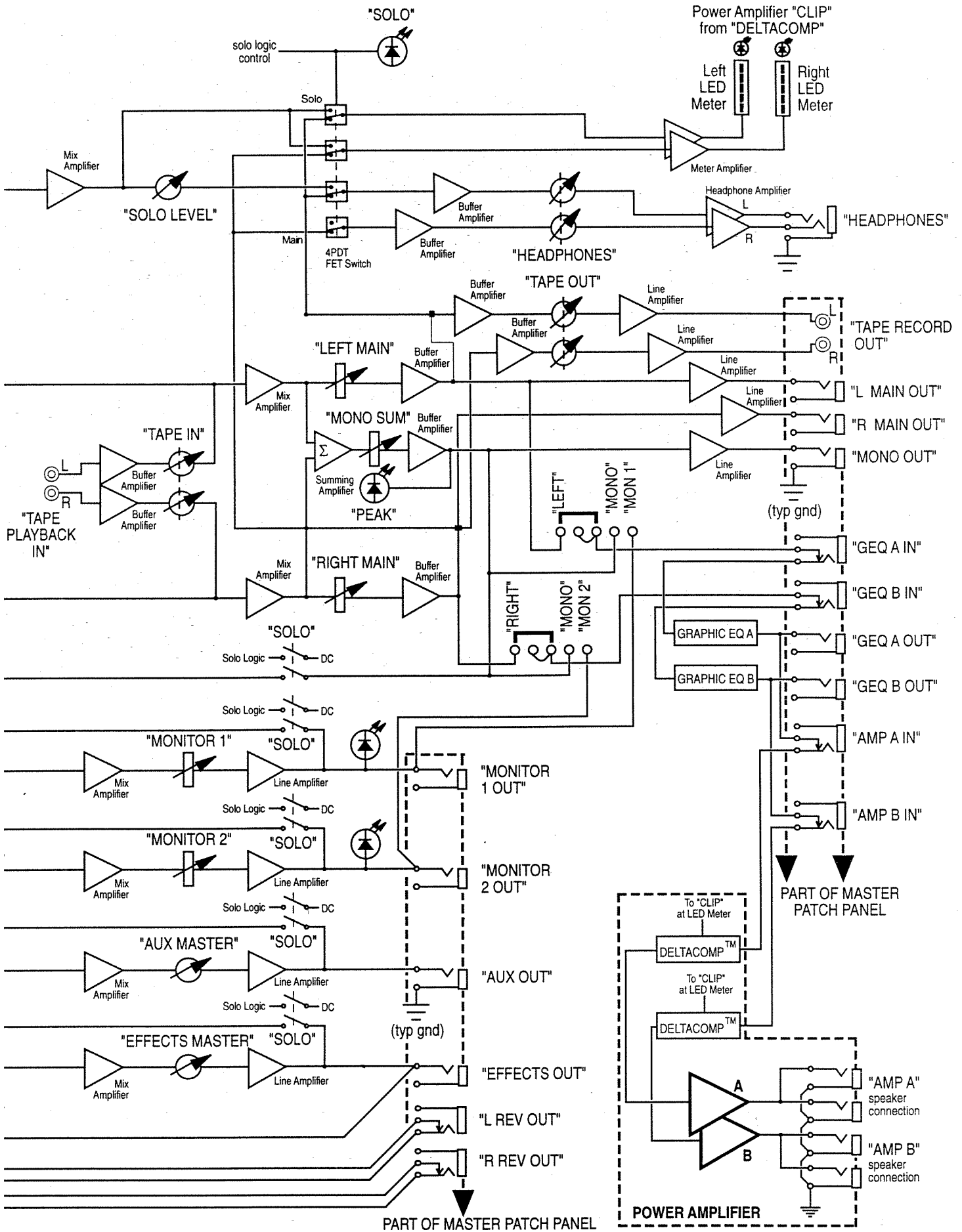

Keep the block diagram handy, and as we work through each section of your PX-2200, note where you are on the block diagram, and you will begin to understand the lay of the land.

An Exercise: Reading The PX-2200 Block Diagram

Each section of a mixer block diagram represents some important function. For example, the triangles represent amplifiers: pre-amplifiers, line amplifiers and power amplifiers. The rectangles represent the graphic equalizers and the reverberation unit. The circles with an arrow through them are controls: pan controls, tone controls, sends, and so on. A small vertical rectangle with an arrow through it is a slide fader. The lines connecting all of these devices represent real wires (or traces on a printed circuit board) inside the Mixer and the vertical lines near the center of the block diagram represent the mix buses (you can always tell a mix bus because it has a large number of inputs connected to it). Additional symbols represent your Mixer's switches, LEDs, meters and input and output jacks.

Page 18 and 19 is the block diagram of your PX-2200 mixer. Now that we have taken a close up look at the elements that make up the mixer, try your hand at following the signal path from where it enters the PX-2200 mixer all the way through to the outputs. If you have trouble, page back through the section to locate the appropriate symbol for review.

Start at the Lo-Z balanced input, which is where you plug in a microphone or low-level source. Notice that, even though your Mixer has at least eight inputs, only one is shown. This simplifies the block diagram considerably, but doesn't reduce its usefulness at all (the inputs are the same anyway).

Just past the Lo-Z input jack, you see a vertical line indicating the presence of phantom power on that jack (provided the phantom power supply is turned on). Then the signal flows through a preamplifier stage. You may also note the line level input that comes from an input jack is attenuated, and combines with the Lo-Z input going into the preamplifier. In this preamplifier stage is the Trim Control, and you can now see how one Trim control can work for either the Lo-Z or Hi-Z inputs (they share the preamplifier stage). One of the inputs to the channel PEAK LED's detector circuitry is also located at this preamplifier stage, so that it can detect signal at either the Lo-Z or Hi-Z input jacks.

From this preamplifier stage, the signal flows through the Input channel Equalization Controls (Low, Mid, and High). These are like the tone controls on your hi-fi, but they only work on the input channel signal, as opposed to the entire mix. Notice also that there are also several inputs to the Peak LEDs detector circuitry (at the output of the mic preamp, the Equalization Control section, and after the Input Channel fader buffer amplifier). This allows you to detect an overload condition anywhere in the input channel.

After the input channel equalizer, the signal is routed to the insertion jack (and through the "normalled" switch located on that jack). If no connector is plugged into the insertion jack, the signal flows through the input channel, through a buffer amplifier, and on to the input channel fader. If an external device is connected to the Insertion jack, the signal will then flow out through the tip of the jack to the input of an external processing device. The output of the external processing device would return into the mixer via the ring of the insertion jack, and then the signal goes on along its merry way.

After the fader, the signal goes through another buffer amplifier (the pan buffer, used to isolate the fader from the Pan and Effect controls), and then on through the Pan control, to the Program Left and Right mix buses.

The signal splits before the equalizer and the fader to feed the Monitor 1 and Monitor 2 controls, which in turn feed the Monitor 1 and Monitor 2 mix buses. Since the signal feeds the Monitor controls before it passes through the Input Channel fader, the Monitor controls are "prefader"; that is, they are not affected by the fader position.

The "Effects/Reverb" and "Auxiliary" send controls, on the other hand, come after the equalizer and the fader and is therefore "post-fader" (it is affected by the position of the fader). The Monitor controls can be changed to "post-fader" by changing the location of a jumper on the printed circuit board (this modification must be performed by a qualified service technician).

After the Program mix buses, the signal flows through a "mix" amplifier. This mix amplifier performs the duty of mixing together the signals from all the Input Channels while keeping them from affecting each other.

Next, the signal flows through the master fader (either left and/or right main). After the master fader, the signal flows through another buffer amplifier, to a "line amplifier", and finally to the "real world" via the main (left or right) Output jacks (and out to any external device connected to these jacks). This signal is also fed to the input selector switches for the graphic equalizers.

Notes:

From the equalizer selector switch, the signal is routed through the "normalised" graphic equalizer input jacks, into the graphic equalizer, out of the graphic equalizer (through the "normalised" graphic eq out jacks), and finally into the "normalised" power amp input jacks, which in turn feeds the signal into the input of one of the two power amplifiers in the PX-2200. Notice that the amplifier "Clip" LED reads the level at the input of the Power Amplifier, and detects overload at the power amplifier, as opposed to the mixing console.

After following the signal flow through the Mixer, you can see how valuable the block diagram can be. As you read the rest of this manual, we suggest that you study the various sections of the block diagram. Experienced mixer operators often keep a copy of the block diagram close at hand at all times to remind them of the way the various parts of the mixer operate and interact with each other.

Got it?Good! Believe it or not, once you know how to read a block diagram, you are well on your way to becoming a mixer maven!

The rest of this page has been left blank intentionally, so you may make notes to yourself regarding the block diagram.

How to use your PX-2200 Series powered mixing console A self-teaching guide

The Artistry of Mixing.

The sound system operator usually has a title having something to do with "technical operations", "sound crew", or some other title implying behind the scenes status (Provided the operator is in the bands good graces. If not, you don't want to know the kind of "titles" that can be thrown at you!).

But as we noted earlier, the sound system operator also deserves to be recognized as an artist, as much an artist, in fact, as the musicians or performers on stage.

At one time, a performance of any type had to be held in a room (or outdoor area) small enough that the performance could be properly heard by everyone in the audience. That just isn't true anymore. Most performances now depend on some type of sound equipment either for sound reinforcement, sound effects, or both. In other words, the sound system has become an integral part of the performance. In fact, many performances simply couldn't be held without a sound system.

Knowing this, the sound system operator faces the responsibility of carrying the audio portion of a performance to everyone in the audience. The orchestra balance, once solely the responsibility of the orchestra conductor, is now in the hands of the sound system operator. The tonal character of an instrument, once controlled solely by the musician, is now controlled by the musician and the sound system operator.

The quality and intelligibility of a voice, once the exclusive responsibility of the vocalist, now depends a great deal on the vocalist's microphone technique and the abilities of the sound system operator.

In brief, the sound system operator now shares a significant portion of the artistic responsibility for a performance, which can be a "performance" of any kind, from a live musical drama to a rock concert to a guest speaker at a place of worship.

As you learn to use your Fender PX-2200 Series Mixer, you will find that it enhances your capabilities and helps you carry out those artistic responsibilities. For that reason, in this manual, we recognize your artistic responsibilities, and we comment on the artistic, as well as the technical nature of the various connections and controls.

The Exercises.

Throughout this section of the manual, we will explain each part of the PX-2200 in an easy to understand manner. Then we will provide you with the opportunity to try out an "exercise", actually using the PX-2200. The purpose of these "exercises" is to allow you to learn how to use your mixer's controls and switches, and begin to appreciate the things you can do during an actual performance. Even though that "performance" may be anything from a large outdoor rock concert, to a special choir service, learning the controls and switches now will get you past

the "mechanics" stage (what happens when I turn down the "Mid" control?) and farther towards the "artist" stage (how can I improve the vocal quality of that nasal-voiced singer?).

At the end of each section, the exercise will be identified by a term such as "**An Exercise: Using the** (insert choice) **Control.**"

The Site.

There's no reason why these exercises can't be done at home in your living room. You may however, want to set up a pair of loudspeakers, one or two microphones, and several pieces of external electronics, and try out the system at higher than living room sound levels! If your living room doesn't give you the required space, or your family or neighbors won't put up with the sound levels, we suggest that you practice "on-site" (wherever your "performance" will take place).

Differences Between Various Models Of The PX-2200 Series.

In these next few sections, we'll discuss the controls and features of the PX-2200 series. If you have a PX-2208D, you have the same controls and features as the PX-2212D or PX-2216D (just fewer Input Channels and slightly lower power). If you have a PX-2208, all controls are the same, except for the digital reverb/effects section, which has been omitted in favor of a built-in spring reverb system. All other controls are the same.

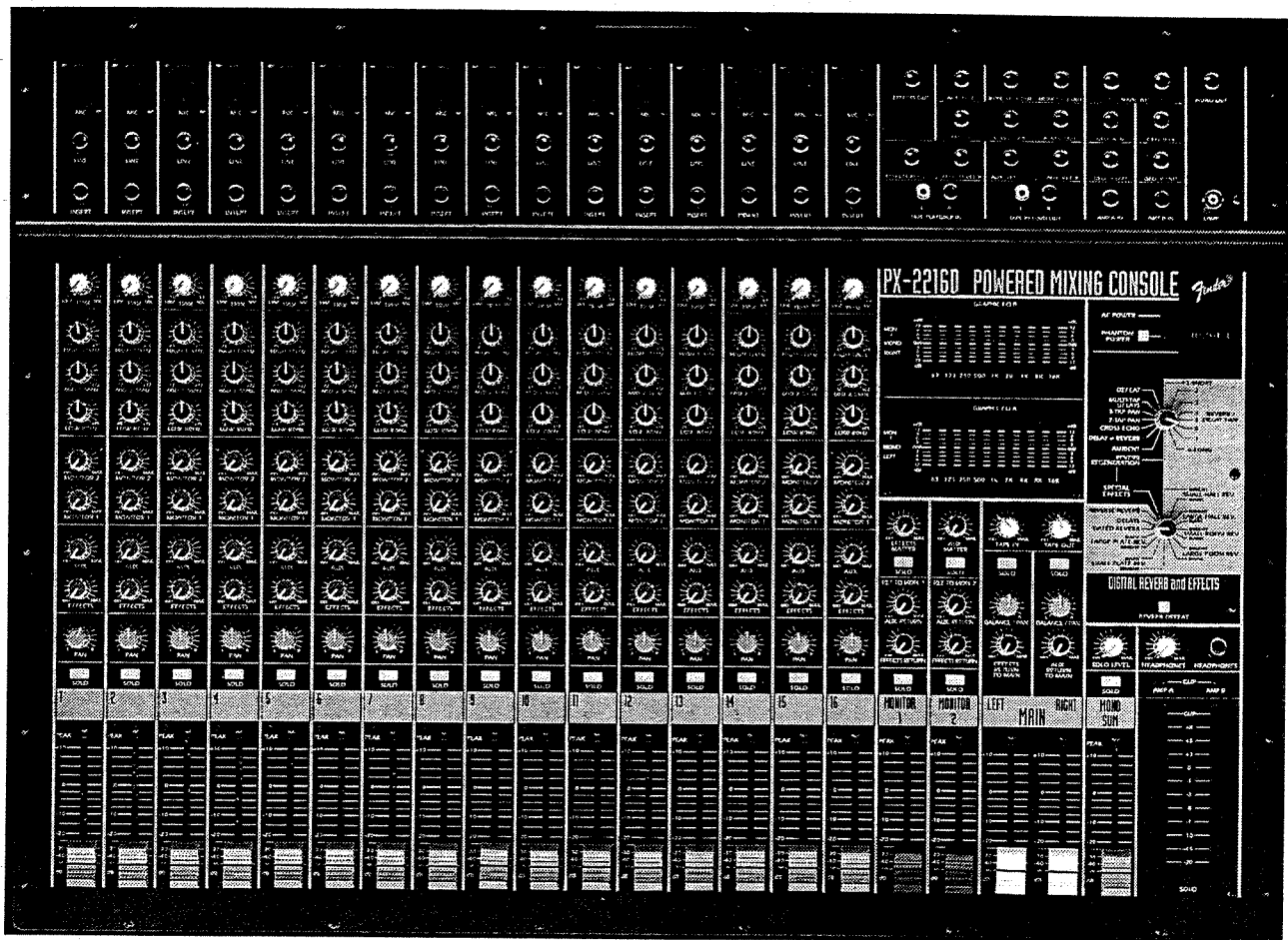

Necessary Equipment.

Your Fender PX-2200 Series Mixer includes just about every piece of electronics you need to perform these exercises. You just add the sources (microphones, compact disc players, etc.) and loudspeakers!

You should have at least one microphone, preferably of the type you'll be using "on the job." If you'll be using several types of microphones, try to get one of each type for your exercise sessions.

For your musical sources use: a compact disc player, or a stereo DAT, or cassette machine (preferably a high-quality, stereo player/recorder like you would use in a home stereo system). You may need a pair of "RCA"/phono jack to 1/4" phone plug adapters". Ask your Fender Dealer about these adapters.

Get a collection of CD's or tapes, and search out some with strong solo instruments (and voices), a clear and open sound, and a wide dynamic range. If you have any doubts, ask your Fender dealers advice for a good demo CD.

We'll pretend that these CD's or tapes are live instruments (which is the reason you should look for good solo passages). Also, prepare a tape of the voice of someone you know very well, and talk with often (your spouse or a close friend is an excellent choice). If that person sings, ask them to sing. If they feel shy about being recorded, have them read from a book or newspaper. The idea is to get the chance to hear how the controls on your Fender Mixer affect the sound of a voice that you know very well. Your own voice, by the way, is a very poor choice for this test!

Remember how foreign your own voice sounded the first time you heard it on a tape recorder? Imagine how the microphone will be used in a live performance, and ask your friend to duplicate those conditions as much as possible. For example, if you will be mixing a live musical performance, the performers will likely hold a microphone close to their mouths and sing loudly. Thus, you should ask your friend to do the same (watch out for the increased bass response in a cardioid microphone used up close).

Choose a pair of full range loudspeakers with at least 200 watts power handling capacity. It's possible that, for this practice session, you could get along with a pair of lower-powered loudspeakers, like your home stereo speakers.

But, if the system unexpectedly goes into feedback (howling), the full 150 to 300 watts will be sent to your loudspeakers! In other words, beware!

There are two Power Amp speaker level output jacks on each output channel of your PX-2200 Mixer. This allows you to connect more than one loudspeaker to each power amplifier in the PX-2200. Just make sure the total impedance connected to each power amplifier is 4-ohms or greater. That means you could connect up to two 8-ohm loudspeakers (one for each Power Amp Out jack) to each power amplifier in your PX-2200 Mixer.

If you expect to be using any auxiliary electronic effects devices, such as an external reverb or a compressor/limiter, bring them to your practice site too.

The PX-2200 Mixer.

What is A Mixer?

The basic point of the entire process of sound mixing, is to bring a wide range of sounds together, amplify them, blend them in a creative mixture, and send them back out in some sort of pleasant sounding whole. The heart of this system is the mixer, or mixing console. By this definition, the mixer is truly the Mother of All Signal Processors, but it's also much more than that.

The audio mixer is like the kitchen of a big fancy restaurant where a dozen chefs are busy working on their particular piece of a fabulous meal. The basic ingredients are brought into the mixing environment, they are moved around to various destinations where additional ingredients are added and blended, and then the entire preparation is carefully placed in position and presented to the diner.

In the case of an audio mixer, the diner is the audience, and the preparation is, hopefully, a feast for the ears.

Inch by Inch & Row by Row... A Mixing Console Close Up

One of the most enticing (and daunting) images in audio is the look of a massive mixing console (whether in a recording studio or in a concert hall). It's simultaneously inviting (look at all those knobs and buttons...) and repelling (look at all those knobs and buttons...), but the key to understanding mixers, is like the key to understanding life; it's all one step at a time.

You're either on the bus, or you're off the bus...

Any mixing console is made up of a certain number of input channels which can be routed (in an assortment of combinations) to a certain number of output channels. Most mixers provide the capability of creating several independent mixes to be used for very specific purposes. These separate mixes are created by sending the appropriate signals from each input to selected **mixing buses**.

What's a mixing bus? Well, it's just like a regular bus, but in lieu of passengers, a mixing bus carries electrical signals. A mixing bus is an electrical line that collects the various signals (passengers) fed to it and sends them to another place.

Through the use of appropriate controls, signals are directed onto a bus wire where they combine, like cars on a freeway, with other signals on that same wire. The signals on each individual bus are prevented from crossing to the other channels that enter the bus, through circuitry designed to keep this freeway running in only one direction (input to output).

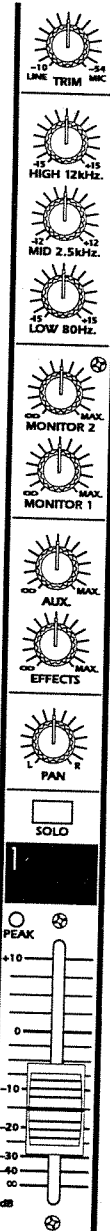
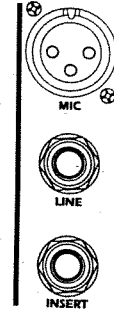

PX-2200 Series Input Module

As the mixer is the heart of the sound system, the mixing buses are the veins and arteries of the mixer. [Okay... so we've got a mixed metaphor; what better place, huh?]

The Mixer Input Module

This module is the long vertical strip of controls that keeps repeating itself across the face of our PX-2200. It controls all of the functions relating to a single input signal, such as a single microphone, or an individual line level source, such as the left or right channel output of a CD player.

The mixer input channels, while clearly being the most impressive element of any mixing environment (due to their sheer number), are by no means as complicated as they look.

Before anything can be done with an audio signal, its got to get into the mixer. How you get a signal into the system, and what you do with it once it's there, depends on what kind of signal it is.

Basically, there are two types of inputs: mic and line. The microphone inputs come in on a three-pin "XLR" type connector marked as "mic", and the line level inputs come into the mixer via the 1/4" phone jack connector labeled "line". The PX-2200 is configured to allow simultaneous operation of mic and line inputs. If both types are plugged into a single channel, they will be mixed together in that channel. Normally however, you will want to only use one input, in each input channel, as this allows you to control the level, tone, placement, etc., of a single input source. And remember, the purpose of the mixer is to *control* each individual sound, letting you "mix" them into a tasty whole that everyone will enjoy.

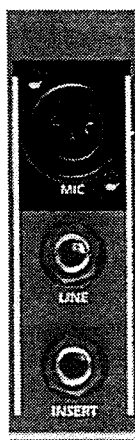

Mic Inputs.

Utilizing a female three pin XLR type connector, the **mic input** accepts the low level microphone signal and feeds it directly to the mic preamps. The output level of a microphone is a very small signal -around .775 millivolts AC. (a millivolt is 1/1000 of a volt).

This proves inadequate to the task of running around a mixing console without picking up enormous amounts of noise and eventually pooping out from exhaustion. In order to accommodate these low voltage levels, virtually every mixer/mixing board has a system of mic preamps as its first input stage. These preamps boost the minimal mic

input levels to a workable line level voltage (approx. .775 Volts, as opposed to .775 millivolts).

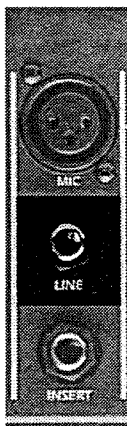

Line Inputs.

The output of many signal sources (synthesizers, tape recorders, outboard effects units, re-verbs, high impedance mics, etc.) have signal levels

that do not need the boost provided by the mixer's mic preamp. The output of a typical line level is around -12 to +4 dBu. The Line inputs comes into the PX-2200 on each channel through the "line" input, utilizing a standard quarter inch 3 conductor phone jack. This input is balanced, although it may also be used with any unbalanced input with no reduction in level.

Once the line level comes into the console through the input jack, the signal goes through an attenuator, that reduces the signal level to that of the microphone input, and then it is fed along with the mic input into the microphone preamplifier.

Mic Preamp.

The mic preamp is the first active stage the signal meets upon entering the mixer.

One of the most important concerns in considering a mixing console is the preamp design.

The mic preamps can make or break the sound of the entire console. Like a bad report card in first grade, noise and distortion introduced at this stage will follow the signal for "all of its life".

The mic preamps in a mixer are not to be confused with the preamps in a typical condenser mic, which are designed solely as impedance converters, and only serve to bring the high impedance output of a condenser microphone "in line" with standard low impedance mics. While the output of a condenser mic will typically demonstrate higher levels than the average dynamic mic, they are still not within the range necessary to drive a line level input.

The microphone preamplifier amplifies the low level microphone signal from around -50 dBu, to a line level around 0 dBu. The actual amount of signal gain at the microphone preamplifier is controlled by the "trim" control. A maximum of 48 dB of gain is available in the PX-2200 microphone preamplifiers.

The Trim Control.

The knob at the top of the input strip—the knob closest to the connectors—is the trim control. This small knob adjusts the gain of the input signal to the mixer, by varying the gain of the microphone preamplifier on each input channel.



The trim control is perhaps the most important element in the mixing chain. It is here that the wide ranging dynamics of an audio program—from the softest stage whisper to the loudest drum kick—are first adjusted to some semblance of uniformity that the rest of the system can handle.

By optimizing the preamplifier gain for different sources, you minimize preamplifier "hiss" noise, and maximize preamplifier headroom.

Because the Trim control is a continuous adjustment, you can optimize the gain for almost any type of input, from a very low-level microphone to a high line-level synthesizer.

The Peak Indicator.

Many mixers will have **Peak Level Indicators** connected to each channel to guide you as you make adjustments to the gain of each individual channel.

Peak level indicators are small red LEDs (located near the faders on the PX-2200) that blink at you when the channel signal is peaking at (or very near) maximum level.

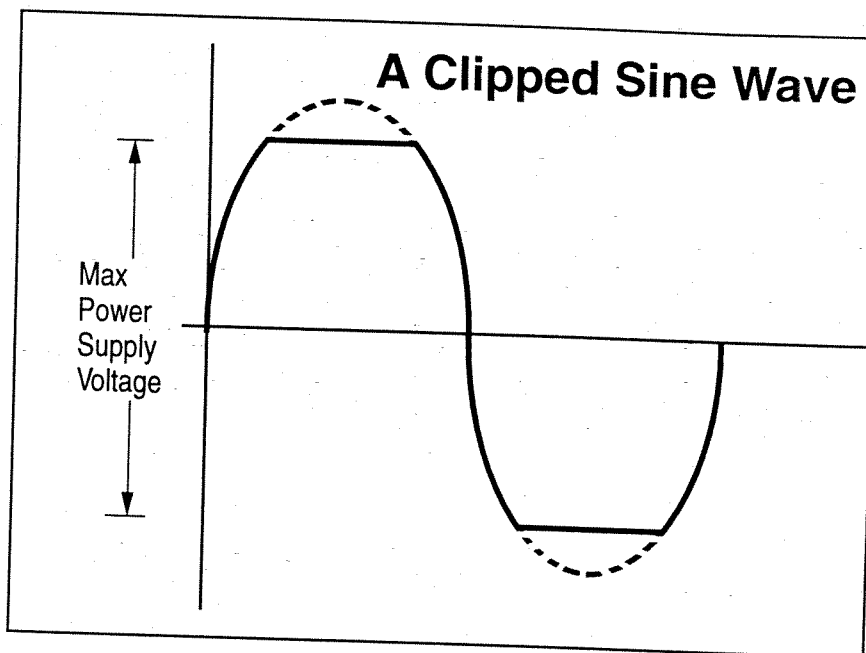

Ideally, these lights will occasionally flicker (your board should be able to handle momentary peaks of a much higher level than the ongoing signal) but you don't want them burning like the light at the end of a tunnel.

If the peak LED is staying on all the time, turn down the trim control.

Before, during, and after you have adjusted the Trim control, the Peak LED gives you important

information on the incoming signal strength. The Peak LED lights when a high-level peak signal is present at the Lo-Z In or Hi-Z Input connector, or when any control is rotated past the point where clipping distortion begins.

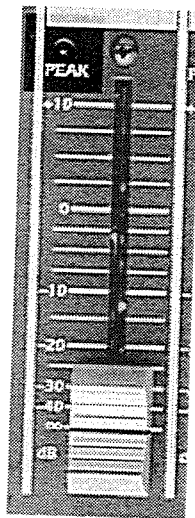

The Peak LED lights up 6 dB before the onset of clipping distortion at any stage in the input channel, and acts as a warning light to the operator, telling him or her to adjust the controls to prevent distortion and overload. Such an overload could occur at the input preamplifier (requiring the trim control to be adjusted), the input channel equalization controls (low, mid, and high frequencies, if a level is boosted above a point where clipping occurs), or at the channel fader. If you rotate a control too far and the input channel Peak LED begins to flash, simply back off the control you just changed, until the peak LED goes off. If you have not adjusted any controls, and the peak LED is flashing, slowly turn down the Trim control until the flashing stops. The Peak LED and trim controls are the same for all Fender PX-2200 Series Mixers.

Input Levels, Dynamic Range, and Headroom.

The speedometer on your car probably has a maximum of about 100 miles per hour. Of course, you never drive that fast, but, theoretically, the car has enough power to be capable of that kind of speed.

Why? Because you need that power for those brief acceleration periods when you pass another car.

Headroom, in a piece of audio electronics, is very similar. It's unlikely, for example, that you will run the power amplifiers in your PX-2200 Mixer full bore all the time (at their full 150 to 300 watts of output power). You will seldom need that much power. Yet, you need it occasionally for the peaks in music and speech.

Examples of these peaks include the sharp attack of an electric guitar, or of a drum stick on a wood block. These peaks may be as high as 10 to 20 dB above the average level of your program, which means they require 10 to 100 times as much power!

This difference between the average and peak levels in your program is known as headroom. Maintaining adequate headroom is important to avoid what is known as clipping, a form of distortion that happens when the signal level is too high in one or more sections of the mixer, and that section overloads, causing distortion. Clipping distortion adds a very "raspy" sound quality to a signal. Since it causes an amplifier to produce excessive power levels, extreme clipping can actually damage your loudspeakers.

Clipping can happen in any piece of audio electronics, but it occurs most frequently in the input sections of a mixer (or preamplifier) and in power amplifiers.

Like a big dumb puppy dog, any amplifier (preamp, buffer amp, line amp, or power amplifier) will loyally attempt to lift any signal that it is fed at the input. When an amplifier is fed a signal at a level that exceeds its design capabilities, clipping occurs.

When the wave form of an audio signal exceeds the capabilities of the amp, the amplifier will flatten out the wave form and continue to produce at maximum power until the wave falls below that maximum level. This creates a very strong impression of a square wave, severely increasing distortion that may endanger high-frequency loudspeakers.

A severely clipped sound wave has the same effect as an overall 3 dB increase in voltage, or double the amplifier's maximum continuous power. In other words, an amplifier with a power rating of 400 watts into an 8 ohm load, can have a power of 800 watts into 8 ohms when it is driven into clipping (as will inevitably occur at some point in a major concert where amplifier power is already being driven to the extreme). If you're not prepared for this, you may find yourself spending the next morning shopping for speakers.

But clipping does not occur just in power amplifiers. Again, clipping can occur at any stage, if it is overdriven beyond the capabilities of the D.C. power supply powering that amplifier. Other terms you will hear in connection with clipping distortion are "squaring up," which means the same as clipping, and "hitting the rails" (the power supply "rails" or voltages), which means the signal is so high, its voltage level exceeds the power supply voltages, which causes clipping.

In most cases, about 10 dB of headroom is considered adequate to avoid noticable clipping. That means the average power from your PX-2200 Mixer's power amplifiers will be about 30 watts (the peak power will be 10 dB above this or 300 watts). Now you can see the importance of a large power amplifier, like those in your PX-2200 Mixer.

In your PX-2200 Mixer, of course, you don't have to think much about clipping or headroom. Just adjust the Trim controls properly, watch the Peak and Clip LEDs and the VU Meters, and listen. If your ears tell you that the sound quality is good, that's a good indication that your adjustments have been made correctly. If you do approach clipping (as indicated on the mixer by the input channel peak LED's, and the VU meters, or on the power amplifier by the power amp clip LED indicators), the PX-2200s Delta-Comp limiting kicks in, providing an extra 18 dB of headroom, and then reducing the gain to help protect against amp clipping. Delta-Comp only works on the power amplifier however. Be careful, and don't just rely on Delta-Comp, as clipping distortion can occur in low level circuitry anywhere along the signal path.

The "Trim" control and Peak LED can help you adjust the gain of the Input Channels in your mixer to avoid Input Channel clipping. Watch the Clip LED (near the channel fader) to avoid clipping the input channel, and watch the power amplifier clipping LED's (near the VU bargraph meters), to prevent clipping the power amplifiers.

An Exercise: Setting Up Your System, And Using The Inputs, Trim Control, And Peak LED's.

Connect the CD player or tape recorder's outputs to the Channel 1 and 2 Hi Z/Line inputs on your Fender PX-2200 mixer. Connect the microphones to the remaining Input Channels, using the Lo-Z inputs for low impedance microphones (as well as high-impedance microphones). If you have a microphone with a 1/4" phone plug connector, you must use an adapter to connect it to the Lo-Z input (see the input wiring diagram on page 65).

T/S Phone Plug to XLR Connector

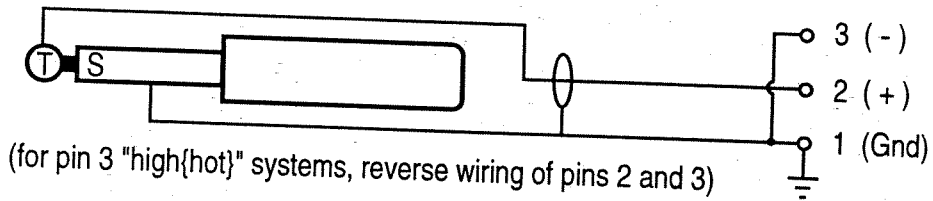

T/R/S Phone Plug to XLR Connector

Use this wiring to connect a balanced, line-level device to the Hi-Z In jack

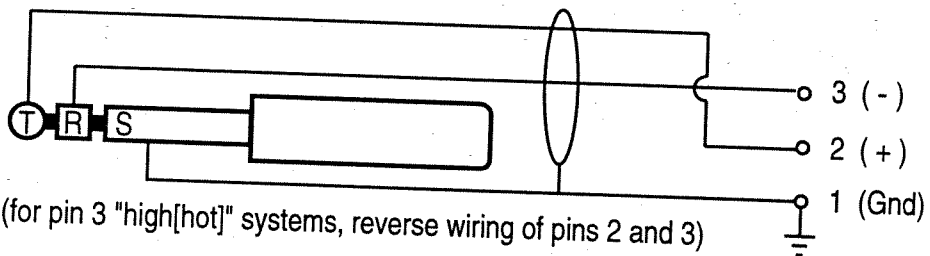

Wiring for a Professional Mixer "Insertion" Connector

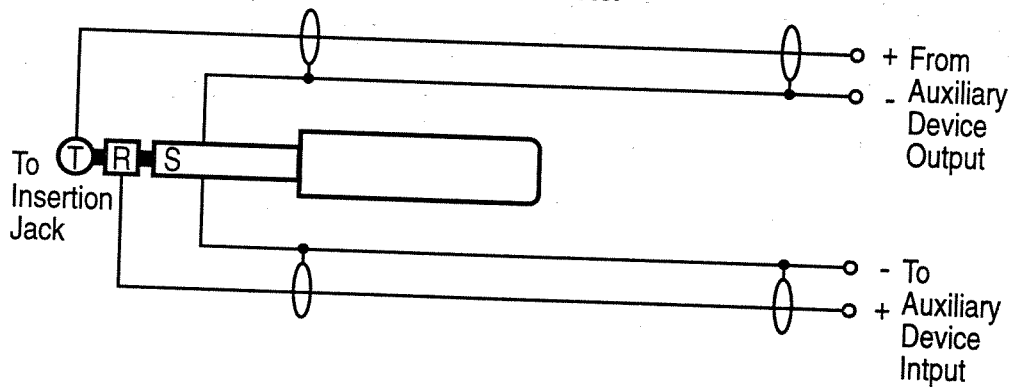

XLR Type Connector

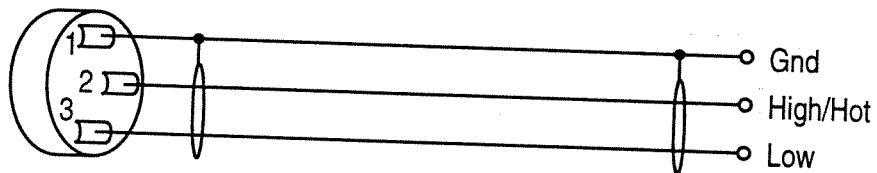

Balanced (for pin 3 "high{hot}" systems, reverse wiring of pins 2 and 3)

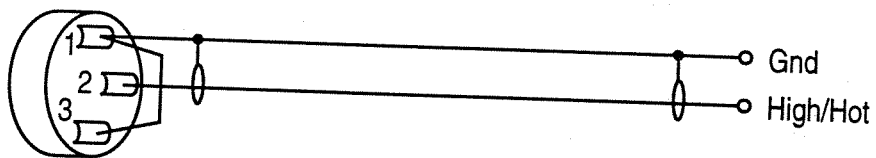

Unbalanced (for pin 3 "high{hot}" systems, reverse wiring of pins 2 and 3)

Similarly, if you have a high impedance microphone, you should use it with an impedance matching transformer. Your Fender Dealer, again, is the most likely source for these adapters. If the adapters come unwired, see the section of this manual entitled "Connectors and Cabling". You may also want to check out the adapter wiring chart found on page 63 of this manual.

If you have any auxiliary devices, you may wish to hold off connecting them until the discussion of the Insertion feature and the Effects mix.

Be ready to connect your loudspeakers to the Power Amplifier Output jacks, and connect the Mixer's AC Power Cable to a grounded 120 volt, 60 Hz outlet.

This equipment (your PX-2200 Powered Mixing Console) is equipped with a grounding type supply cord to reduce the possibility of shock hazard. **DO NOT ALTER THE AC PLUG!**

WARNING: This equipment must always be properly earthed (grounded).

WARNING: This unit has no user servicable parts inside, refer servicing to qualified personnel only.

If you are using your Fender Mixer outside the USA, confirm that the AC Power voltage, current and frequency are correct for all of your electronic equipment.

The Initial Control Setup.

Before turning on the AC Power Switch, set all faders (slide volume controls) at their "infinity" (fully down) positions. Set all pan controls and input equalizer (low, mid, and high) controls at the center detented positions. Also, center the slider type graphic equalizer controls.

Set all other rotary type volume controls (Reverb/Effects, Auxiliary, Monitor, Input Gain, etc.) at their "0" positions (fully counterclockwise). All front panel switches should be in the "up" (not depressed) position. The slide switches on the graphic equalizers should be set to the position closest to you, marked "left" and "right" respectively.

Turning It On.

Some types of audio electronics produce a sharp "thump" when they are first turned on. This is called a "turn-on transient".

Some audio devices also produce a similar noise when they are turned off (a "turn-off transient"). While these transients are usually harmless, in some cases they can reach high levels and represent a danger to your loudspeakers.

While we have designed your PX-2200 to have a very low turn-on and turn-off transient, other pieces of equipment that might be plugged into the PX-2200 might sound like a firecracker going off (or on), and the PX-2200, being the obedient servant it is, will just sit there and amplify that bang!

To protect against such loudspeaker damage, it's a good idea to turn on your entire system, without any program material playing. Always turn on all outboard equipment plugged into the PX-2200 first, and then turn on the PX-2200 last. When shutting off, go in the reverse order, by turning off your PX-2200 first, followed by all the other gear.

Using The Peak LED.

Choose any tape or CD from your collection and start your tape machine or CD player. Now, while watching the Peak LED, turn up the Trim control (clockwise) on the input channel you have the player plugged into, until the Peak LED

begins to blink on and off regularly.

Now turn the Trim control back down just a bit, so the Peak LED blinks only occasionally. That's all there is to it! You have just optimized preamplifier gain for maximum headroom and minimum noise!

Now repeat the process for all the other inputs you're using. For microphones, talk or sing into the mic while you are adjusting the Trim control (or have a friend do the talking/singing). Talk or sing at approximately the same level you would expect in a performance (for a musical performance, this may be much higher than normal speaking voice).

Once you have set the Trim controls on all channels, you should not have to reset them unless you plug something different into the input, or there's a drastic change in input level (like a strong-voiced singer replacing a very weak-voiced singer).

Using the Trim Control.

Before an actual performance, you should perform a Trim control adjustment on each Input Channel. As you become familiar with your equipment, you should be able to judge the proper settings for the Trim controls from experience. If the same singer always uses the same microphone, for example, you'll be able to set the Trim control in the same place each time (and probably just leave it there if you always use the same Input Channel). Watch the Peak LEDs. The Peak LED can help you determine the relative level of two different inputs (whichever input is loudest will light the Peak LED more often). However, if the Peak LED stays on for more than an instant, or if it lights frequently, you may be experiencing some "clipping distortion", and you should probably readjust the Trim control downward slightly.

Phantom Power For Condenser Microphones.

Before we move on from the inputs, the mic preamplifier, and the trim control, we should mention the phantom power feature of the PX-2200 series.

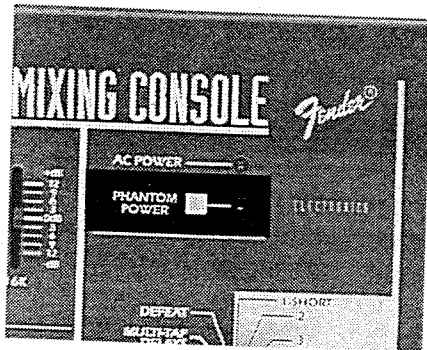

An Explanation of Phantom Power.

Your Fender PX-2200 Series Mixer provides phantom power (via the phantom power switch and internal circuitry) for powering condenser microphones, if desired. Phantom power is the DC (direct current) power required for most condenser microphones (and some other items like active direct boxes) to operate. Although some electret condenser microphones also run on batteries, if they run out in the middle of a performance, you're sunk! By powering the microphone from the mixing console, you can be assured of uninterrupted operation. The reason it is called phantom power, is due to the fact that the D.C. power for the microphone is "sneaked" down the same set of wires as the A.C. audio signal from the microphone, without affecting the sound or the performance of the mic. The +48 volt D.C. Phantom power is supplied to pins 2 and 3 of all balanced Lo-Z microphone input connectors, with pin 1 for ground (common), whenever the "Phantom" power switch is engaged.

If any of your chosen microphones require phantom power, turn the phantom power switch "on" (depressed). The phantom power switch is located next to the red Fender Electronics logo in the upper right hand side of the mixer panel. When it is depressed, a red LED will light, showing that phantom power is on. Don't worry, the phantom power supply won't harm any non-condenser microphones, nor will it cause any performance changes.

In other words, you can leave the Phantom switch "on" all the time if you want to.

Adapters and Phantom Power.

You might use an adapter to connect a microphone with a 1/4" phone plug to the XLR Lo-Z input connector on your PX-2200 Mixer. While, on some mixers, this adapter would short out the phantom power, it is perfectly acceptable on your PX-2200 Mixer. The Phantom power will not work on the channel that has the adapter plugged in, however. In other words, go ahead and use adapters as needed, even when you are using your PX-2200 Mixer's Phantom power feature. Again, Phantom power only shows up on the balanced Lo-Z microphone connector, and not on the 1/4" line level/Hi-Z input jack.

Auxiliary Equipment and Phantom Power.

Some types of direct coupled auxiliary equipment could be harmed by being connected to the Lo-Z Inputs of your PX-2200 Mixer when the Phantom power is turned "on". While this is unlikely, it's a good idea to check with the manufacturer of the auxiliary equipment if you have doubts about this connection (or plug the auxiliary equipment into some other input, such as the Hi-Z/Line Input).

Mixer Input Channel Equalization (Tone Controls).

Like the residents of George Orwell's Animal Farm, all sounds are created equal, but some sounds are more equal than others. As you listen more carefully to the sounds around you (both in and out of a concert situation), you will begin to be able to identify their various frequency ranges, as well as the ranges where there is "too much" or "too little".

Minor adjustments in the level of the signal at more isolated frequencies will allow you to get a better sound out of a specific instrument or vocalist in a particular situation.



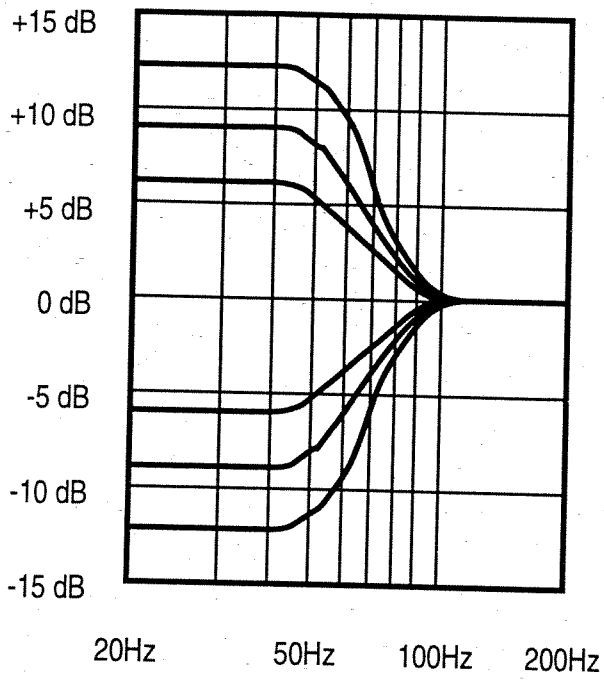

Chart A

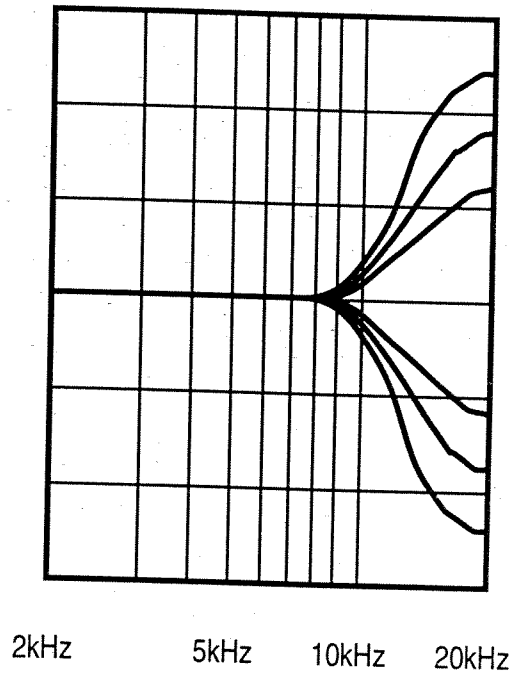

Chart B

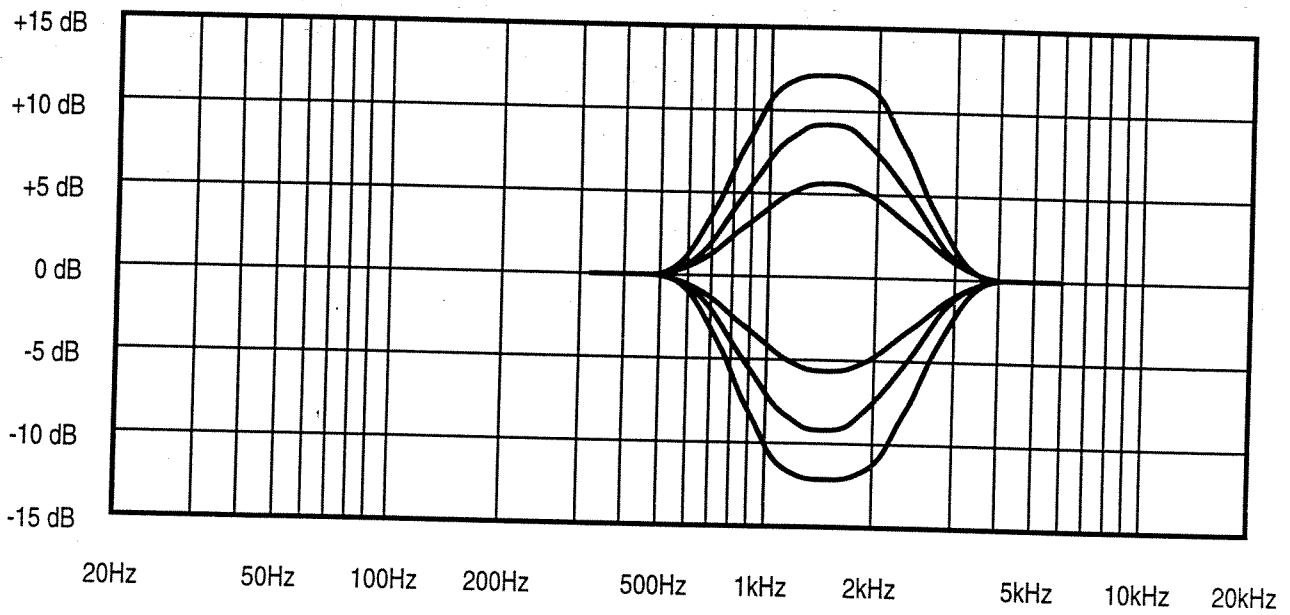
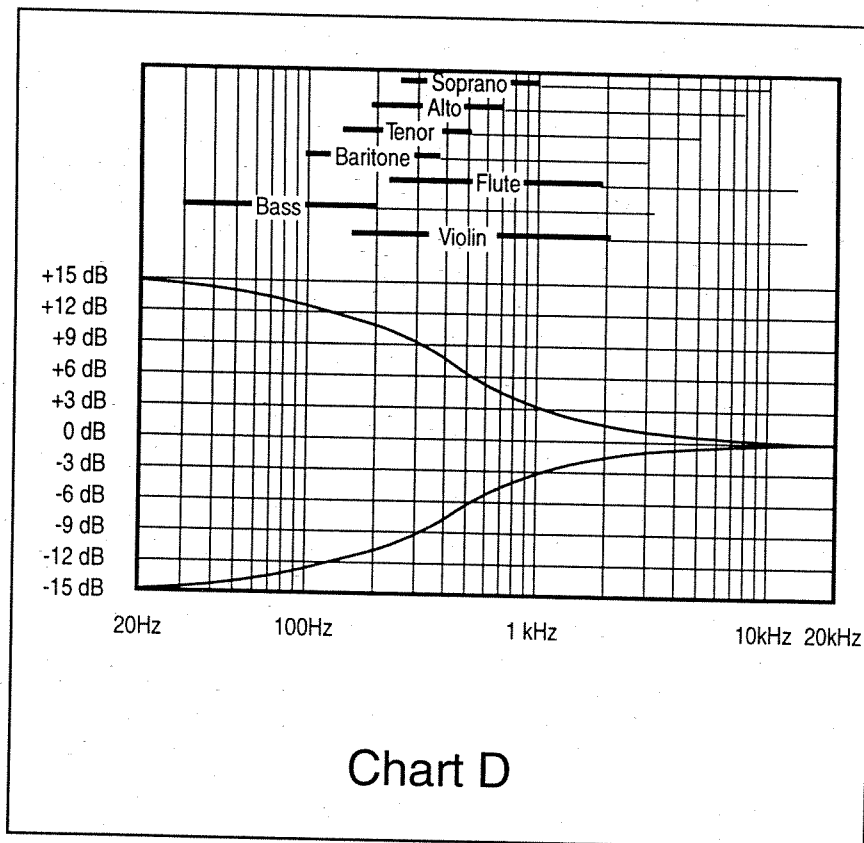

Chart C



What the Input Channel Equalization Controls Do.

The Equalization controls have much the same effect on the frequency response of the Input Channel as the tone controls on your stereo system have on its frequency response. The purpose of these controls is to give you the ability to alter the frequency response of a voice or instrument to improve its subjective sound quality. Here, in fact is the place where you can really show your skill as an audio artist!

In order to understand the various elements of the EQ section, it is necessary to have a handle on a few basic concepts:

Center Frequency.

The **center frequency** of an equalizer is the reference point (frequency) from which the EQ. is measured.

Bandwidth.

Also known as the Q, the term **bandwidth** describes the width of the affected frequency area surrounding the selected center frequency.

Amplitude.

The amount of boost or cut that occurs at the center frequency (measured in dB) when that particular equalizer control is moved from center (Ø cut/boost).

Types of EQ.

All mixer input channel EQ's are made up of one or both of the two basic types of equalization circuitry: shelving and peak/dip. Like much of what we have already considered, the names are largely self-explanatory.

Shelving EQ.

Shelving EQ affects all the frequencies above, (for high frequency EQ), or below (for low frequency EQ) a selected frequency.

This is the most basic form of EQ, and most people are familiar with it as the "tone controls" of simple stereo units (i.e. bass and treble). It is called "shelving" equalization because it basically creates a frequency shelf to which all affected frequencies are raised or lowered. Chart "A" on page 31 shows a low frequency shelving control, while chart "B" shows a high frequency shelving control.

Peak/Dip EQ.

The other basic form of equalization allows for a cut or boost of the signal to be applied to an area of frequencies surrounding a selected frequency only, with certain adjacent frequencies affected to a lesser extent (depending on the bandwidth of the control). This is referred to as peak/dip equalization, because the center frequency is "peaked" when boosted, or "dipped out" when cut. Chart "C" on page 31 shows a peak dip midrange control.

The PX-2200 Input Channel Equalizers.

The equalization circuits on the PX-2200 mixer input channels are a high frequency and low frequency shelving EQ, with peak/dip equalization at the mid range frequency. This type of an input equalizer is referred to as fixed EQ. A fixed EQ will allow you to cut or boost the signal level for a specific bandwidth around specific frequency ranges.

The straight lines in Chart D above shows the frequency range of an electric bass guitar and a flute. Don't confuse this term "frequency range", which shows the highest and lowest notes that can be played on the instrument, with the similar term "frequency response", which normally applies only to electronic devices and not to musical instruments.

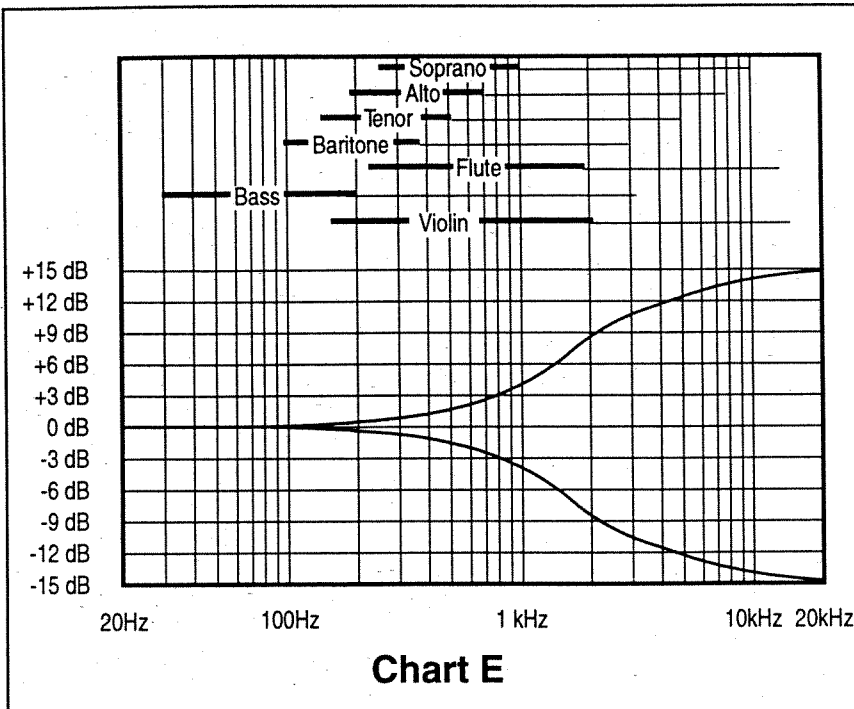

Also keep in mind that the range of upper harmonics will vary from instrument to instrument (thus, these charts are not exact). The curves show the changes in Input Channel frequency response produced by boosting or cutting the "Low" control (bass tone control). You can see from these lines that the Low control can have a significant effect on the sound of an electric bass, but will have much less effect on the sound of a flute. The curves in Chart E above, shows the changes in Input Channel frequency response produced by the "High" control alongside the same electric bass and flute frequency ranges. Here, it's apparent that the High control can have considerably more effect on the sound of the flute than the electric bass.

The curves in Chart "F" on page 34 shows the changes in Input Channel frequency response produced by the "Mid" control. The dark lines show the frequency range of a typical male and female voice as well as the electric bass and flute shown in Charts D and E on pages 32 and above.

Here, it's apparent that the Mid control can cause significant changes in the sound quality of all these instruments. In other words, of the three controls, the Mid is the most powerful and probably the most important.

Finally, the solid lines in Chart "G" on page 34 show the changes in frequency response of a typical cardioid microphone for different microphone to-voice distances. The increase in bass response of a cardioid microphone at short microphone-to voice distances is known as "proximity effect" and is discussed in more detail in the section on "Choosing and Using Microphones".

In some cases, you might want to use the Low Control to reduce this proximity effect. In other cases, you would welcome the increased "warmth" the proximity effect can add to a voice.

Also note the slight rise in the high frequency response of this typical cardioid microphone. This is a planned feature of the microphone, known as a presence boost.

It can help bring out the sibilants (consonant sounds) in a voice. In some cases, this presence is desirable, in other situations, you may wish to reduce the presence of a microphone with the High control (such as in the case of excess "nasality" in the tone of a voice).

An Exercise: Using the Input Channel Equalizer.

If you haven't already done so, read "The Exercises". Be sure the pan control is centered, the EQ controls (low, mid, and high) are in their center (detented) positions, and the Channel fader is all the way down.

Select a series of CD's or tapes with lots of different instruments again. Use solo instruments whenever possible. Try a low-frequency instrument first, like an electric bass or organ.

Set the main Left and Right faders for a comfortable volume level from your loudspeakers. Now, while playing the tape or CD, experiment with the Channel 1 Low control. Can you make the instrument sound more or less "mellow"? Notice that the Low control, because it affects most of the frequency range of the instrument, almost acts like a volume control for instruments with a range in the low frequencies? Keep the same tape running and reset the Low control back to its center position.

Now, try out the Mid control. What effects does the Mid control have on the "sharpness" of the sound quality? Now, reset the Mid control to its center position, and, with the same CD or tape still running, try out the High control.

You probably won't notice much effect on the sound of the bass instrument. You may notice an increase in hiss!

(Tape hiss is primarily a high frequency phenomenon). You may also notice an increase in presence in some bass instruments which have an appreciable high frequency content (lots of high harmonics), a synthesizer, for example.

You may wish to try these same experiments with high frequency instruments like a flute; and with several midrange instruments like saxophone, violin and piano. You can also do some pretty amazing things to the sound of a good drummer with the Input Channel Equalization controls. In other words, the best way to understand the operation of the Input Channel Equalization controls is to find CD's or tapes of as many different instruments as possible, and experiment!

One "instrument" you should work with in this exercise is the human voice. If, for some reason, you didn't get a tape of a friend's voice, find a tape or CD from your collection with a solo singing voice. You want one with as little reverberation and effects as possible. An acappella voice would be ideal. If you have a choice of male and female, choose one and then do this exercise over again with the other.

If there are two of you doing this practice session, now is the perfect time to try out your microphones. Do these exercises with a microphone instead of your tape machine or CD's. And do something more original than testing, one, two. If you don't want to sing (the best way to try out this set of controls), then at least read something from a book or magazine to get some variety into these tests!

Try to make the voice sound "warmer" (or less "warm"), by using the Low control. Notice the effects the Mid control can have

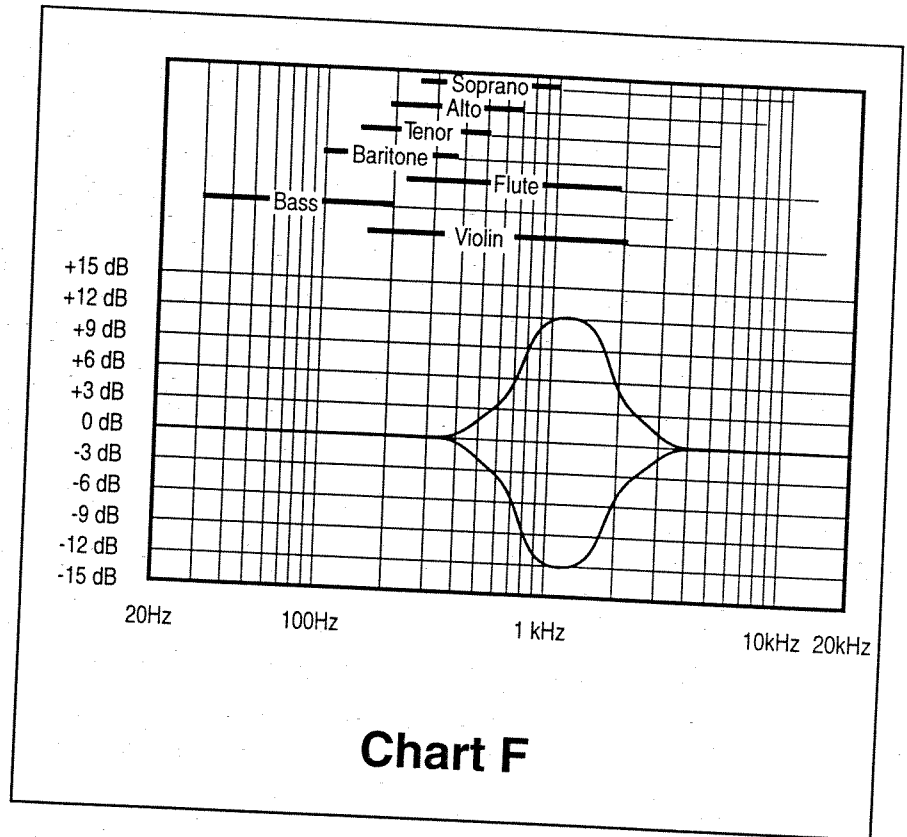

Chart F

on the relative "harshness" of the voice. Depending on whether the voice is male or female, and on the particular voice qualities, you will probably find that some combination of all three bands (low, mid, and high frequencies) is optimum for controlling this particular voice. Some other voice, of course, might respond better to a different setting. Now, try the High control and notice its effect on the presence of the voice. You can emphasize or de-emphasize

the sibilants (high-frequency consonant sounds) in the voice with the High control. You can also affect the sibilants, to a lesser degree, with the Mid control.

If at all possible try out the Input Channel Equalization controls with a live voice (other than your own), and your various microphones. Not only will you discover the difference between live and recorded signals, you will hear the differences among the various

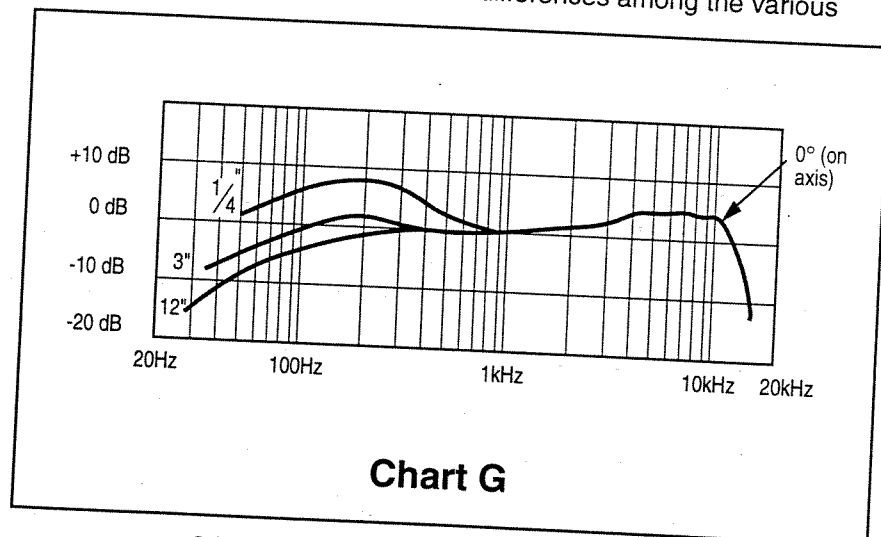

Chart G

microphones. Listen, in particular for proximity effect, an increasing bass boost noticeable in many cardioid microphones as the talker moves closer to the microphone. How would you counter this effect if it was excessive? Also listen for the difference in presence (high frequency response) in the microphones. How would you increase presence if it were lacking in a microphone (or voice)? Try to correct for a twangy nasal voice.

The Input Channel Equalization Controls and Mixed Instruments.

Now that you have a good idea of the effects of the Input Channel Equalization controls on solo instruments, it's time to try out your skills on an ensemble!

Find a CD or tape with a group of instruments, and at least one voice. An "uncluttered" piece of music like a country or folk song would be ideal. Avoid a piece with lots of reverb and complex effects.

Run both channels of your tape machine or CD player, and use both Channel 1 and Channel 2 on your Fender Mixer. Bring the faders up to a comfortable listening level.

This is a simulation of a real performance. The only differences are that you don't have individual control over the various inputs and that there will always be some differences in the sound of live versus recorded sources.

Nevertheless, you can try out some live performance techniques here. In particular, you should attempt to isolate particular instruments and increase their apparent level. Since you don't have individual volume controls for each instrument, on the tape, you are limited to using the Input Channel Equalization controls.

For example, you should be able to bring out the voice(s) with the Mid control. You might even be able to emphasize the voices on Channel 1 and the bass instruments on Channel 2. The importance of this exercise is that in a live performance, you can use these techniques to emphasize a particular voice or instrument without increasing the volume level. There's a lot more to "mixing" than just fader settings!

In a live performance, you may find that the Input Channel Equalization control settings you used for an individual instrument during a practice session, just doesn't sound the same when there are other instruments (or voices) present. This is a normal effect of a live mix.

The point is, there is no right or wrong way to set the Input Channel Equalization controls for a particular instrument or voice! What is important is the subjective sound quality you achieve during an actual live mix. Think in terms of the entire mix! If the piano sounds like a piano (and the other instruments and voices also sound "correct" during the actual performance, then you've done your job right!

A Precaution About Over-using Input Channel Equalization.

Equalization is a very powerful tool. Used carefully, it can significantly enhance your artistic capabilities. Used to excess, it can actually hinder the process of sound reinforcement.

The trick is to use the Input Channel Equalization controls in a subtle way, like an artist uses a fine-line paint brush. Over use these controls by turning them too far up or down, and you risk excessive noise, distortion, phase cancellation problems, and a very unnatural sound quality.

We'll discuss equalization in more detail in another section. For now, don't hesitate to use the Input Channel Equalization controls, but remember that it is very rare to need more than 3 dB to 6 dB of boost or cut for the vast majority of voices or instruments.

The Insertion Point

On every input channel of the PX-2200, there are the two input jacks (mic and line), as well as a third jack, the "insert" jack. While the jack itself looks identical to a line input jack, its actual makeup and purpose, is quite different.

Generally the insertion point is a TRS (tip-ring-sleeve) connection (like a standard 3 conductor stereo headphone jack), that will allow you to remove the signal from the board (the send point, which comes out on the jack "tip"), send it to another piece of equipment, come out of that other piece of equipment, and bring it back again into the mixer (the return point, which comes in on the jack "ring") with a common ground for both (the sleeve). Almost always, this insertion point connection is **normalled**.

Unlike some of the musicians you may work with, there is something to be said about being normalled, but it has little to do with being in the mainstream, having a house in the suburbs, 2.4 kids, a dog, and a station wagon! A normalled connection is a tip-ring-sleeve jack with an internal switch between the tip and sleeve contacts.

If no plug is inserted, the switch closes the circuit and the signal flows along its normal path (normally connecting the tip to the ring). When a connector is plugged into this circuit, the switch is opened and the signal is routed along the connector's path (out through the tip, back in through the ring).

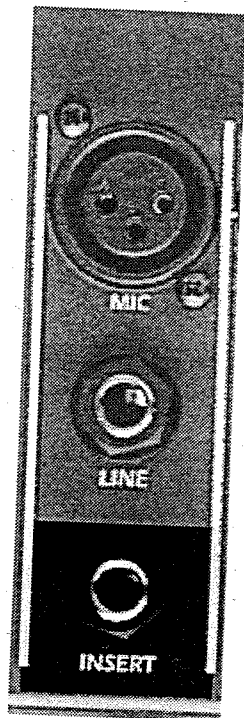

The Input Channel Faders.

After the signal has come out of the equalizer, and through the insert jack, it is routed to the channel fader.

While the faders are certainly the most visually commanding feature of a mixing

console, it is really a small element in the rather complex system that is a modern mixing board. The term "fader" comes from the stage lighting business, where a slide-type control "fades" the light level up or down. In audio, a "fader" is a slide-type control that "fades" the sound volume up or down. Faders are more desirable than rotary volume controls on a professional mixer, since you can see their individual positions, and their relative positions (the mix) at a glance. In addition, faders are a better human interface than rotary controls. It's easy to bring several faders up and down with one hand, but almost impossible to do the same with several rotary controls.

For this reason, rotary controls are used for functions that you can pretty much set and forget (like the Trim control). Faders are used for more active functions - like mixing!

While the fader may occasionally be used to raise the level of gain on a channel, a fader's primary purpose is precisely that, to attenuate—to fade or lower the signal in order to blend the various elements together.

With most mixers, there will be some indication (a 0 dB reference, a shaded area, or some other symbol) of where the fader should be set for nominal level when originally setting the input signal at the trim control. From this point, you will generally bring the fader back in order to create the necessary level adjustments for your mix. However, if you find that you're having to bring the level consistently toward the bottom of its throw, you may want to readjust the trim control in order to give yourself more room to maneuver with the channel fader.

Conversely, if you find that you generally do not have enough gain and run out of room at the top of the fader, you may need to raise the input gain slightly at the trim.

An Exercise: Using The Faders.

See "The Exercises" if you haven't already done so. Start your CD and set the input gain control like you did in the previous exercises. Then, set the Main Left and Right (master) faders to their "0" positions (nearly 2/3rds of the way from the top of the fader's travel). Now, slowly bring up the fader on Input Channel 1, and listen to the music from your CD player or recorder come out of your loudspeakers!

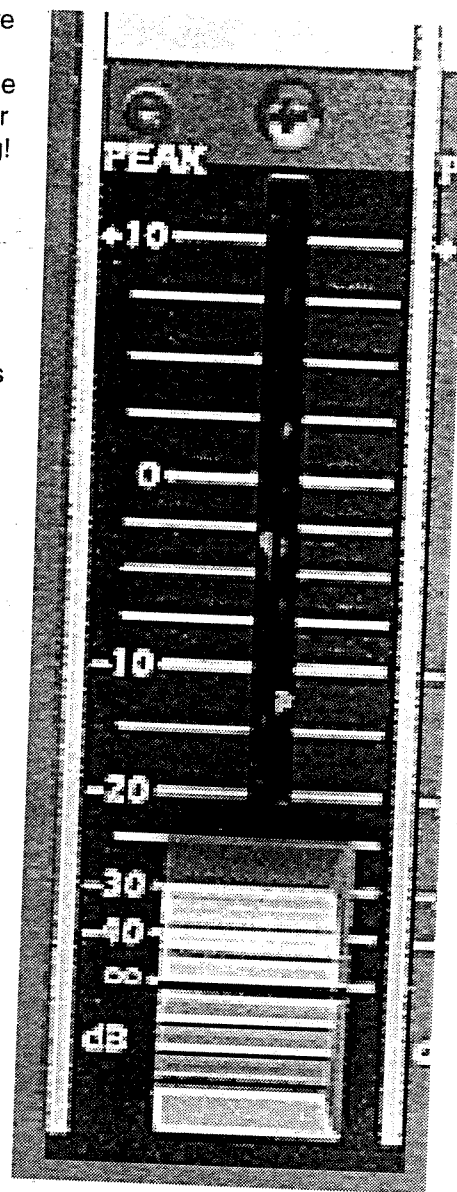

Go ahead and bring the fader up to a comfortable listening level, but avoid turning the level up loud enough to cause distortion. Keep the VU meter indication at or below the "0 VU" position for now (we'll talk about the VU meters later). Note that even though only one Input Channel is operating (which is connected to the left output from your CD or tape machine), both of your loudspeakers are making music. This is because of the centered position of the Pan control. Leave the Pan control centered for now, we'll get to change its position in a minute or two.

Now, slowly bring up the fader on Input Channel 2 to the same position as the Channel 1 fader (after setting the input trim control on channel 2 properly). Now, both the left and right outputs of your CD or tape machine are being routed to your loudspeakers, but they are mixed together in mono. To confirm this, turn down one of the master output faders at a time (either left or right) and note that the sound from both loudspeakers is, indeed, a mix of the left and right channels from your tape machine or CD.

Next, bring the level of the Main Right fader all the way down. Now, alternately mix the Input Channel 1 and Input Channel 2 faders up and down which will alternately bring the left and right outputs of your tape machine into the left loudspeaker. If you wish, try the same procedure with the Program Left fader all the way down. In a very real way, you are "mixing" these two "sources" (the CD or tape machine outputs) to your loudspeaker.

Establishing a Balance.

The 0 position (also called the "nominal" position) should be considered the ideal setting for the Main L&R (master) faders. Of course, you will change the position of the inputs faders continuously as a normal part of mixing a performance, and may need to slightly boost or cut the master left and right faders occasionally.

The exception to this would be a gradual fade out, where you would pull down both the main left and the main right fader, to "fade" out a song. For normal operation, however, keeping the Program faders at or just below their 0 position has two important benefits:

First, it gives you "maneuvering room" to mix the output levels up or down at will. If you keep the master left and right faders too near the top or bottom of their travel, you limit your ability to increase or decrease the output level.

Second, keeping the master left and right faders near their 0 positions, along with careful setting of the Trim controls allows you to mix the Input Channel faders at positions that are reasonably near their 0 positions.

This mixing technique establishes a balance between Trim control, input fader and master fader positions that gives you maximum maneuverability and also optimizes the signal-to-noise ratio inside the mixer.

What is a "Mix" or a "Mix Bus"?

In Latin, the word "omnibus" means "all." In audio (and in the English language), the word "mix" usually is used to describe the way an operator adds together all of the inputs and routes them to an output. For example, if we are talking about the main Left output channel, we may refer to that as the Main Left "Mix" because all the inputs have been "mixed" into the main Left Output (before they get to the Program Left Output, they are "summed" onto the main Left "mix bus," see next paragraph). Similarly, when we talk about the Monitor 1 "Mix", we mean that group of inputs which, by use of the Monitor 1 control on the Input Channels, have been "mixed" onto the Monitor 1 Output (via the Monitor 1 "mix bus").

A "bus" or "mix bus" is a physical connection point where the outputs from of a group of Input Channels (or other signals) are physically connected together (we often say the signals are "summed" on the mix bus).

The mix buses in your Fender PX-2200 Mixer are shown as continuous vertical lines on the block diagram. If you study the block diagram for your Mixer, you can see how all of the Input Channels are connected to the main Left and main Right mix buses, for example.

The "Pan" Control.

"Pan" controls appear in each Input Channel, on the Aux. Return section, and on the Reverb/Effects Return section. When used for stereo mixing, each channel of your board needs to be assigned to its appropriate place in the stereo panorama. The **pan pot** (very short for "panoramic potentiometer") accomplishes this quite handily. The term "pan" is adapted from "panoramic," as the term is used in the movie business. To "pan" a camera, while filming a movie, means to swing it from one side of a scene to the other to show the audience a "panoramic" view. In audio, to "pan" an audio signal means to vary the volume of the signal from one loudspeaker to another, which makes the apparent source of the audio move from one loudspeaker to the other. A "Pan" control performs this function, by panning a signal between the Program Left and Right buses. This is how the signal from each input channel is routed to the stereo master left and right busses.

How A Pan Pot Works.

The pan pot adjusts the amount of signal flow to each of two channels in a stereo mix. Each pan pot consists of two variable resistors, wired in such a way that as the level of one increases, the level of the other decreases.

When the pan knob is set in the middle of its throw (centered at its detent at 12 o'clock), it will send an equal amount of signal to both channels of a stereo mix.

As the knob is moved to the right, the signal level sent to the right channel is increased while that sent to the left is decreased (and vice versa). The amount of signal sent to each side is dependent on how far to the extremes of left and right the knob is turned. This has the effect of allowing you to "position" an instrument or vocal anywhere within the stereo field.

Technical note: If both sections of a pan pot maintain full output when the pan is at center, there will be a 3 dB boost of the signal. In order to avoid this bump, the resistance curve of a pan pot in a quality mixer should be designed so that the separate channel signals are attenuated by 3 dB (half the power) when the pot is at center. In this way the total power coming from the system remains constant throughout its range of movement.

Operating the Pan Control.

Besides its ability to move the apparent source of a sound from one place to another, the Pan control may also be used to position an instrument (more or less permanently) at some point between two loudspeakers. This widens the apparent size of the sound source, at least for people sitting in an area where they can hear both loudspeakers (i.e. true stereo).

The Pan control can also be used to send entirely different mixes to the master Left and Right outputs. You might do this if your two loudspeakers were pointed at entirely different areas in a room (an "L" shaped club, for example), or if you wanted to use the stereo master busses as two independent sub-groups (when used with the mono sum output).

For example, put a vocal subgroup on the left master, and the rest of the instruments on the right master, and then use the mono sum master as the mono mix feed to one or more of the power amp sections of the PX-2200.

If, as in most situations, at least some part of the audience cannot hear both loudspeakers well, it is a good idea to avoid panning an Input Channel entirely to one side or the other. That would cause it to disappear from one loudspeaker and part of your audience would then not hear that input in the mix.

This same situation, where at least part of your audience cannot hear one of the loudspeakers well, often prevents you from doing a true stereo mix (a mix where the apparent placement of instruments in the mix corresponds to their physical placement on stage).

The sound system operator is, in a sense, the representative of the subjective tastes of each member of the audience. This is one reason experienced operators always try to position themselves (and their mixer) in an "average" seat. Typically, this "average" seat will be about 1/3 of the way back from the performance area, and slightly off center to avoid the frequent bass-frequency build up near the center of an audience area.

Positioned in this average seat, you can hear the results of changing the Pan control setting, for example, and you can be certain that such an action has enhanced, not degraded, the mix.

An Exercise:

Using The Pan Control.

If you haven't already done so, read "The Exercises". Then, while playing your CD or tape machine, fade the Channel 2 input all the way down.

Set the master Left and Right faders at equal levels. Now, bring up the channel 1 fader to a good level, and then turn the Channel 1 Pan control all the way counter-clockwise, toward the "L" (left) side. Notice that the sound is now coming entirely from your left loudspeaker and that the Left VU Meter is the only one showing any activity. Try turning the Pan control all the way clockwise to the "R" (right) position. The sound is now coming entirely from the right loudspeaker and the Right VU Meter is doing its thing while the

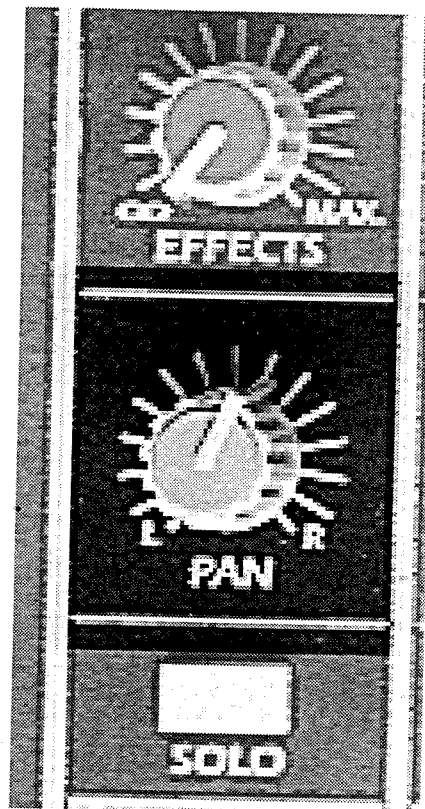

Left VU is off. "Pan" back and forth for a while to get the "feel" of the control. Then set the Channel 1 Pan all the way left and set the Channel 2 Pan control all the way right. Now bring up the Channel 2 fader. Presto! Stereo! Channel 1 (the left channel of your CD or tape machine) is feeding only the main Left output (your left loud-speaker). Channel 2 (the right channel of your CD or tape machine) is feeding only the main Right output (your right loud-speaker).

Try a "cross-fade" by simultaneously turning the Channel 1 Pan control all the way right, and the Channel 2 Pan control all the way left. The sound mixes to mono and centers. then splits again, with the image reversed from its original position. This could turn out to be fun!

SOLO.

It's January 17, 1993, and Michael Jackson is standing on the steps of the Lincoln Memorial amid 3 dozen other performers (including the newly elected President of the United States), in front of thousands, performing for millions, and his mic doesn't work.

He's standing up there, doing an excellent impression of Marcel Marceau doing an impression of Michael Jackson, while everybody else sings America the Beautiful along with Ray Charles.

What happened to his mic!?

One of the ways to track down a specific problem with an individual input in the midst of a massive (or even a not so massive) mix is with the Solo feature. It's very easy in the midst of a large concert setting to get so deeply enmeshed in the proverbial forest, that you can't see the proverbial trees. The solo options on a mixing console allow you to examine the lay of the land, one tree at a time.

The solo system on the PX-2200 works by switching the soloed channel (be it an input or an output) to the headphone monitor amplifier, and to the appropriate LED bargraph meter. When a solo switch is pushed, the stereo main mix which normally appears in the headphones and meters is interrupted, and the solo signal is routed to the headphones and meter.

This allows you to listen to an individual source, as well as to meter either the level at the insert point (on the input channels), or the output level of a soloed master. There are many types of "solo" buttons named for their position in the signal path. These include:

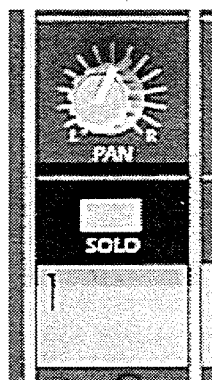

PFL.

PFL (referred to as a Cue switch on some mixers) stands for pre fader listen (or pre fader level if it is connected to a meter). PFL allows you to

examine an individual channel before it reaches the fader, by sending that channel's signal directly to the headphone monitor and meters. PFL provides the advantage of checking out what's going on with any channel without altering your mix. You can track down a vocal ("Oh, there he is on 17!"), or the possible source of distortion or noise. On the PX-2200, the input channel solo switches and the effects and aux. return solos are PFL solos. PFL is a post eq signal, giving you the added advantage of being able to listen more closely to the sound created by your various eq adjustments.

AFL.

You may have already guessed that **AFL** stands for after fader listen. The AFL button not only gives you a glimpse of the solo signal, but also a sense of its overall level. AFL solos are most often used on outputs, as it allows you to meter and monitor exactly what is coming out of that particular output jack.

On the PX-2200, AFL solos are used on the Stage Monitor Masters (1&2), the Mono Sum Master, the Effects master, and the Aux. master.

AUXILIARY SENDS.

The overall utility control, **auxiliary sends**, offers the flexibility of having multiple independent mixes separate from the main left and right mix buses. On the PX-2200, these are the four green knobs on each input channel. When you look at these four green knobs, you will find two auxiliary sends marked as **Monitor 1** and **Monitor 2**, and two more marked **Aux.** and **Effects**.

The two sends marked Monitor are intended for creating up to two independent stage monitor mixes, so the musicians on stage can hear themselves to play better. They can also be used for other functions (which we will describe later). The send control marked Effects, is "normalled" into the built in digital reverb and effects section of the PX-2200. The send marked Aux. is intended to provide a second effects mix to an external special effects processor, although it may be used for a different purpose, if desired. Regardless of what they're named on the front of a particular mixing board, there are two basic types of auxiliary sends, named for the point where the signal is intercepted in the input channel block diagram (also sometimes referred to as the pick off point): *pre-eq./pre-fader*, and *post eq. /post-fader*.

Pre-fader Sends: Monitor 1 & 2.

A **pre-fader** send branches away from the signal path before the channel fader. This means that as you adjust the level of the main signal via the slide fader, you have an affect on the main mix, but you have no affect on the auxiliary signal.

If you fade the channel out of the main mix, it will remain on the send channel, provided that the pre fader send control is up.

When you only want to "pick off" a copy of the audio signal, unaffected by equalization or level changes, you want to make use of the **pre-fader/pre-eq** auxiliary sends: stage monitor 1 & 2.

The Input Channel Monitor controls are pre-fader and pre-EQ. The Output Channel Monitor master faders are completely separate from the Left & Right Master Output functions.

Post-Fader Sends: Effects & Aux.

The meaning of post-fader sends should be fairly obvious. Coming after the signal processing that is done for the input channel signal (EQ and level adjustment), the post-fader signal is often sent to reverb or delay units, *allowing you to fade the effect as you fade the channel.* Additionally, a post-fader effect (which is always post-eq) allows you to make the same frequency adjustments to the effect as you're making to the channel signal. If your channel fader is all the way off, there will be no signal, even if the post-fader send control is all the way up. On the PX-2200, the **effect** and **aux.** sends, are post-fader, allowing you to fade the effect along with the main signal.

There may be times, however, where you may want to use a pre-fader send for an effect in order to achieve a specific goal.

A pre-fader reverb, for example, will allow you to fade the main signal, but leave the signal in the effect.

This can create the illusion of someone fading off in the distance (moving the source off into the distance while the reverberation effect remains the same).

This can be done by two methods. First, you can repatch, using the patch bay in the upper right hand side of the PX-2200 mixer panel. This would allow you to use one of the pre-fader sends (monitor 1 or monitor 2), and route that send into the digital reverb section input jack. The other way is to modify your Effects and/or Aux. sends on the PX-2200 to pre-fader operation. However, this modification should be done by a qualified service technician, and performing this modification voids the warranty. This modification can be helpful, however, especially if you wish to use the aux. send as another monitor mix.

An Exercise: Using The Monitors.

If you haven't already done so, read "The Exercises". You'll need additional connections to try out the Monitor mixes (Do it, it's worth while to find out how these important mixes work). You can either use a separate power amplifier or switch the internal graphic equalizers and power amplifiers in your PX-2200 Mixer.

If you want to use one (or more) of your PX-2200 Mixer's internal power amplifiers and graphic equalizers for stage monitor purposes, use the master graphic equalizer assignment selector switch (located next to graphic equalizer "A"),

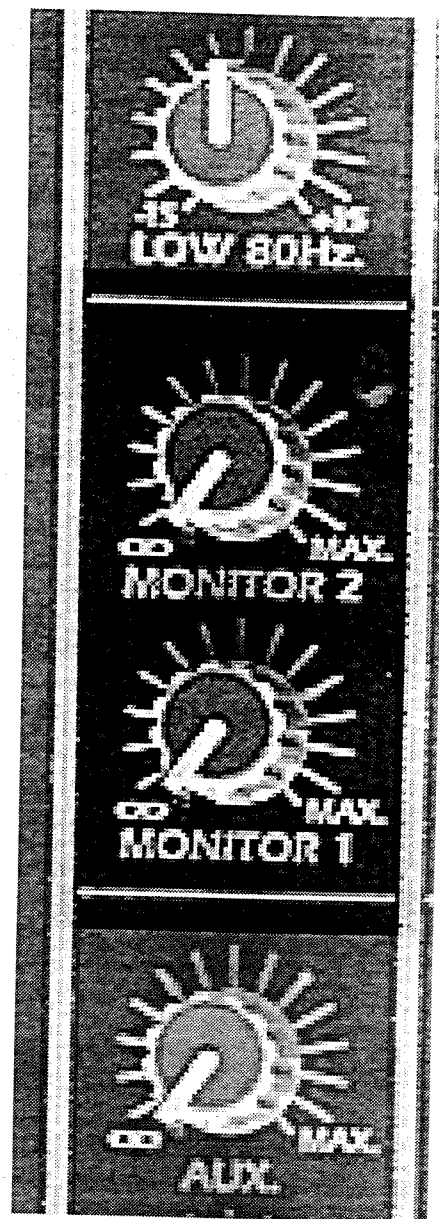

and switch it up to the "Mon. 1" position (see front panel features for a description of these important switches). By doing this, the output of stage monitor mix 1 will be routed to the input of graphic equalizer "A", and out of the graphic equalizer "A" into the input of power amplifier "A".

All you need to do to use this as a stage monitor system now is to plug your monitor speaker into the speaker output jack of power amplifier "A". If you don't have a monitor wedge, the loudspeakers you are using for these exercises will work fine.

Although convenient, if you wish to run a stereo sound system or two mono mixes, using the built-in power amplifiers and graphic equalizers on the PX-2200, it will be necessary to provide a separate power amplifier, and if desired, a graphic equalizer.

We recommend using the Fender M-300 Stage Monitor Amplifier, which includes powerful controls for controlling feedback, altering the sound of the monitors, and a moderate-size power amp, perfect for driving a single pair of monitors. If you wish to use a separate power amplifier, such as the Fender M-300, connect its input to the Mon. 1 out jack (at the mixer patch bay, **not** at the speaker output of amplifier A), and connect the M-300's speaker outputs to your loudspeakers. If you wish to use the graphic equalizers on the PX-2200 as well as the notch filters on the M-300, see the suggested hookup charts in the rear of this manual.

Now that we are hooked-up, let's turn the Monitor 1 and Monitor 2 output faders all the way down, as well as all of the monitor mix send controls (both monitor 1 and monitor 2) on each of the input channels. Make sure that no solo switches are pushed in anywhere on the console. To see if any input channel, effects returns, or output masters are soloed, check the red solo LED near the bottom of the two LED bargraph meters. The solo LED should be off.

When you "solo" any input channel or output master by pushing the solo switch, this LED will turn on. The purpose of this LED is to show you when any input or master channel is "soloed" in the metering and headphone monitoring system.

When an input channel or output master is soloed, the meter and headphone circuit is disconnected from the stereo main left and right outputs, and is switched to whatever input, output, or groups of inputs and outputs that are selected by engaging their respective solo switches. This allows you to meter the level of any signal (to help set input gain, or to meter any of the sends or the mono sum output), and to monitor it by headphones. This can be very useful.

Turn on your CD player or tape machine. Press the "solo" switch above the Monitor 1 master slide fader. This automatically switches both the left VU meter and the headphone monitoring system from the main left output, to the Monitor 1 output. The Solo LED should now light.

Bring up the Monitor 1 send control on Channel 1 to its center position. Now bring up the Monitor 1 output fader until you reach a comfortable listening level.

Re-adjust the two controls if you wish to bring them both into their "nominal" positions (about mid-point for the Monitor 1 Input Channel control).

Now, move the Channel 1 fader up and down, and then all the way off. Notice that the Monitor level does not change! In other words, the Monitor 1 function is independent of the position of the Input Channel fader.

Again, Monitor 1 is "pre-fader" which means that the connection to the Monitor 1 control comes at a point in the block diagram before the signal has passed through the Input Channel fader.

Disengage the monitor 1 solo switch (above the monitor 1 master fader). Bring down the monitor 1 master fader, and the channel monitor send 1 level control. Now, try the same experiment with the Monitor 2 control and the Monitor 2 master output fader. Is Monitor 2 also pre-fader? (Clue: It should be!)

Try altering the tonal quality of the Monitor 1 or Monitor 2 mixes with the Input Channel equalization controls. You will see that these controls do not affect the Monitor 1 and 2 mixes!

In addition to being pre-fader, we can also say that the Monitor mixes are "pre-EQ", which means that the connection to the Monitor 1 and 2 controls comes at a point in the block diagram before the signal has passed through the Input Channel equalization controls.

You may also wish to experiment with the Trim and Pan controls. The Pan control affects only the Master mixes and does not affect the Monitor mixes. The Trim control affects the Monitor mixes in the same way it affects the Master mixes, because it is the first control in the block diagram, and both the main and the monitor sends come after it.

That means you can set up the Trim control just once, and it will be right for both the Monitor and Master mixes. Be cautious about altering the setting of the Trim control during a performance, however.

You (the system operator) will normally be unable to hear the on-stage monitor loudspeakers. Yet, a change in a Trim control setting could affect your monitor mix drastically. In other words, a change in the Trim control could significantly alter your on-stage Monitor mix or greatly increase the possibility of feedback.

Using both the Monitor 1 and Monitor 2 mixes is very similar to using the Master Left and Master Right mixes, even though you use a rotary control (the monitor send control) instead of a fader and a pan pot to put the signal on a mix bus (in this case the monitor bus 1 & 2, instead of the left and right main bus).

Some Helpful Tips On Stage Monitor Mixing.

The magic of live music happens when people hear each other, interact with each other, and *play* off of each other, building an overall level of energy that gets the audience on their feet. As important as a main P.A. system is for the crowd to hear the performance, a stage monitor system is every bit as important for the band to be able to perform properly, and unfortunately it's one area that is very often overlooked.

Set up properly, a good monitor mix can give you a consistent point of reference, regardless of where you play. For the band, and for the band's sound engineer, having good stage monitoring equipment alone is not enough. Even the best equipment can sound terrible if not used properly, and can cause more problems than they solve (i.e., excessive feedback, muddy stage sound, fisticuffs over bad mixes, etc.). Getting a monitor mix that every one is pleased with is no easy task.

Mixing monitors, whether in a small club, or on a touring concert level, is probably the hardest job in audio.

The Purpose of Stage Monitors.

At their simplest, stage monitors are basically complete sound systems turned around to face the performers, as opposed to the audience. They are intended to reinforce the level of certain performers and instruments, bringing them up to the level of other members in the band. This keeps them from being drowned out by louder instruments (such as drums, guitar and bass amps). This is particularly important in the case of vocals, certain acoustic instruments, and some electronic keyboards and percussion (where on stage keyboard amplifiers are not used).

Monitors are also useful to help keep timing and *pitch*, and, in general, for the musician to know what is happening and what they are putting out. Particularly in large halls, where all you may hear on stage is the reflected sound of the house system off the back and side walls, a good quality monitor system is crucial.

Due to the musician's location on stage (i.e. their proximity to another player), or due to their individual requirements to play off of another player (such as in the case of the drummer and bass player), different musicians may need a different mix than others in the band. On stage, for example, a drummer may want a mix that emphasizes the vocals and de-emphasizes the drums. A vocalist may want a mix that de-emphasizes the instruments, but emphasizes the vocals and has just enough drums to help the vocalist keep on time.

In a stage monitor system, since you are aiming a loudspeaker right at a microphone and a performer, feedback can be a royal pain. Even without the problem of feedback, it is important to remember that the purpose of a stage monitor system is to hear everyone at the right levels. It is not a challenge just to get the monitors so loud that everyone's ears bleed! Nor is it like a main P.A., where you are trying to "throw" a signal to the rear seats in the hall. Once again, the purpose of stage monitoring is to equalize the band and reinforce your signals to the point everyone can hear and play off of each other. Having excruciatingly loud stage monitors and/or lots of them on stage can often "muddy-up" the entire sound of the band in the main PA as well as the monitors, even if you're not fighting feedback. Monitor speakers will leak into open microphones and, whenever multiple speakers are used, spread across the stage, their signals overlap. Time delays will result based on the distance the speaker is from the performer. Although the same signal is fed to each speaker at the same time, the acoustic energy from the speaker nearest you will hit your ear first, followed by each successive speaker that is further away. These very short time delays cannot often be discerned as distinct sounds from an individual source, but instead are perceived as a muddy sounding system- with a lack of detail and clarity. Because of this, it is often good to take a minimalist approach (i.e. less is more).

Use just the number of speakers and the on stage level you need for everyone to hear properly, and turn microphones down or off when not in use.

TYPES OF STAGE MONITOR LOUDSPEAKERS.

When most people hear the word "stage monitors", they immediately think of wedge style speakers on the floor, angled upwards and aimed at the performers. While floor wedges are the most common types of stage monitors, there are other types as well.

Wide area "fill" speakers are often used, either on the sides of the stage (side fills), towards a group of players, or even flown over the stage (overhead fills). In certain applications, headphones and even small "spot" monitor speakers may also be used.

Floor Wedge Monitors.

One of the big advantages to floor wedges is that they are typically angle up directly at the musician, and many have a tighter horizontal coverage pattern than a typical p.a. speaker (i.e. horizontal high frequency dispersion). That is why the H.F. horns on Fender stage monitors, for instance, are oriented vertically, giving more even coverage as the performer moves back and forth from the microphone, with minimum coverage side to side. This helps to eliminate overlap between speakers (see mud above), allowing each performer (or groups of performers such as two vocalists right next to each other) to have their own monitor, with little interaction between speakers. As such, floor wedges are most often used as a form of "spot" (as opposed to "fill") monitoring. Floor wedges are often the most flexible type of cabinet to have, as most can be positioned two or three ways, and can double as side fills if needed.

Side Fill Cabinets.

Any good sound reinforcement speaker can be used as a side fill cabinet. Usually, these are larger cabinets than the floor wedges, and are often full range or multi-way p.a. speakers. Side fills can have many benefits. First, they can cover a larger area than a floor wedge, allowing several musicians to use a single speaker. Secondly, since they are often located right behind or below the main house p.a. speaker stacks, they can help alleviate the empty feel many stages have without significant time delays (especially in larger, more reverberant halls). Third, they can be used for a mix of those signals all the performers need more of, while "spot" monitors can be used to provide an individual player the specific instruments they need (such as a bass player and drummer in order to keep time). Used at a reasonable level, side fills can be very helpful, especially on larger stages and in larger halls.

Overhead Fills

Except in very special situations (and usually only in permanent installations), overhead fill monitors should be avoided. They are difficult to rig for a small band, and can be problematic if not set up properly.

Headphone Monitors

Stage monitoring with regular headphones is popular with some players, particularly drummers. Additionally, many larger groups now use "in ear" monitoring systems, comprised of a wireless receiver and small ear pieces molded to an individual's ear shape. If the entire band is using headphone monitors, and there is little chance for feedback, this can be a good option, though some performers have complained of feeling "cut off" from the audience. If not done properly, using headphones can have tragic conse-

quences. Massive feedback, static pops, a dropped microphone, or feeding a high level tone burst accidentally into the monitor system could cause irreparable hearing damage.

For this reason, the use of headphones and stage monitor loudspeakers together is highly discouraged.

WHY USE A PRE-FADER SEND FOR MONITORS

Generally, the Monitor sends are pre-fader and pre-eq. The reason for this is that it's usually not necessary to eq. the monitor mix the same as the house mix. In fact, it can be downright problematic! Signals that are boosted in the house mix (for example to make an adjustment for acoustic deficiencies in the room or to boost certain high or low frequencies that maximize the sound the audience hears) may cause feedback in the monitor (because of the close proximity of microphones to monitor speakers). Additionally, *the optimum sound for the players may be significantly different from the optimum sound for the audience.*

One minor precaution about the Monitor 1 and 2 mixes. At the end of a performance, or during a break, you will probably bring down the Master Left and Right faders to keep stage noises from reaching the audience. Remember to bring down the Monitor 1 and 2 master faders too! Since the Monitor mixes are entirely independent of the Master mixes, they will keep operating normally, even when the Input Channel faders and the Master Left and Right faders are all the way down! This means, for example, that the audience near enough to the stage to hear the stage monitors, could still hear stage noises or even feedback if a technician moves a microphone to the wrong position during a set change.

If you are using wireless microphones and a performer walking off stage forgets to turn off their transmitter, the off stage conversations (did you see that idiot in the front row....) will continue to come through the monitors too!

One way to avoid having to remember to turn down the Monitor mixes is to have a qualified service technician perform the Monitor "post-fader" modification to your PX-2200 Mixer. That way, when you turn down the input channel faders, the input channel monitor controls (because they are now "post-fader") are also effectively turned down. This can also be helpful should you desire the equalizer to also affect the monitor mix, or if you want to be able to use a single control (the fader) to reduce or increase level equally on all the monitor mixes (assuming you are using more than one) equally, without varying the trim or the individual monitor send level controls. It all really comes down to your preferences, and the style of working you find most comfortable.

This modification is probably undesirable for experienced operators who like the idea of a totally independent monitor mix. Pre-fader monitor sends are pretty standard, however, so an operator coming in from outside would probably prefer a pre-fader send.

Our recommendation is to leave the monitor send controls pre-fader, unless you are the only one who will use the board.

K.I.S.S.

Stands for "keep it simple stupid!", and is great advice when it comes to creating a monitor mix everyone is happy with. Once you have your monitors set where the band is fairly happy, leave it alone. Do not try to actively "mix" the stage monitors, changing levels and effects. This is extremely important.

If there is one thing musicians hate, it is a soundman who is trying to constantly alter the stage monitor mix. Once your monitors are set up to the bands satisfaction, DON'T CONSTANTLY TWEAK WITH IT!

This makes performers extremely uneasy and unsure of their performance. Think of the monitors as a point of reference. If the ground is shifting under your feet all the time and you don't know where you stand, you start to worry.

For better or worse, with smaller clubs and bands, usually the person running sound for the main house p.a. will also handle the stage monitor mix. One of the key things to remember in setting up a monitor mix is to start by talking to the band. Find out what they want and need in their monitors, and give them just that, starting with a good vocal mix. Keep it simple, and people will usually be much happier.

Before the band ever hits the stage, or the house ever opens, buzz the system out and ring out the monitors in a pre-sound check, sound check. Have one person (preferably with ear plugs or other hearing protectors) on stage, to help you buzz out the system. Play back a CD you know in the house system, and equalize it until it sounds right to you.

Once that is done, bring up all the mics to the level they will have to be at in the performance, in the house p.a. system. Correct for feedback as necessary.

When the house mix is set, bring up the vocal mics in the monitors one at a time, to the point where they feedback. Use corrective filtering from a graphic eq or a notch filter as needed and find the threshold of feedback. Turn it down from that point by at least four dB.

Then, while the first mic is up, bring up the next mic and repeat the routine, then the next, etc., until all vocal mics are at the right level, and the system is not howling, ringing, etc.

Finally, with all mics up to the right level, bring the overall stage monitor system master level up until feedback begins to occur, make the last filter corrections, and then reduce the master stage monitor system gain by at least six dB. From that point, you can proceed to sound check with the band, and tweak the system until everyone is happy.

Using The PX-2200 As A Separate Monitor Console.

In some venues, you may want to use another console for the "front of house" mix, and your PX-2200 Mixer exclusively for stage monitors, mixed from the side of the stage. To do this, you will need a mic splitter/snake, that splits the microphone signals to the front of house mixer, and off to a separate on stage monitor mixer (The PX-2200).

When the PX-2200 is used for stage monitor mixing, the Monitor 1 output will feed one set of monitors, and the Monitor 2 output will feed another set. This would use both of the internal power amplifiers and graphic equalizers of the PX-2200 for equalizing and powering Monitor 1 & 2.

The Effects and Aux. sends (if modified for pre fader use) could be used to feed two more monitor mixers (Monitors 3 & 4) using external amplifiers and graphic equalizers. The left and right main outputs could be used for a pair of side fill monitors, also using external graphic equalizers and power amplifiers. This would give a total of six separate monitor mixes. While most small bands won't need this kind of diversity in monitor mixing (two mixes,

one for vocals and one for drums or keyboards will usually be enough in a small club), this kind of dedicated monitor mixer is common in larger entertainment systems, and it is illustrated in the System Example (System 6) in the rear of this manual.

THE EFFECTS AND REVERB SYSTEM OF THE PX-2200

The effects/reverb system of the PX-2200 is actually comprised of three sections; 1) the send (mix) from the mixer, 2) the internal reverb/effects unit, and 3) the effects return section of the mixer.

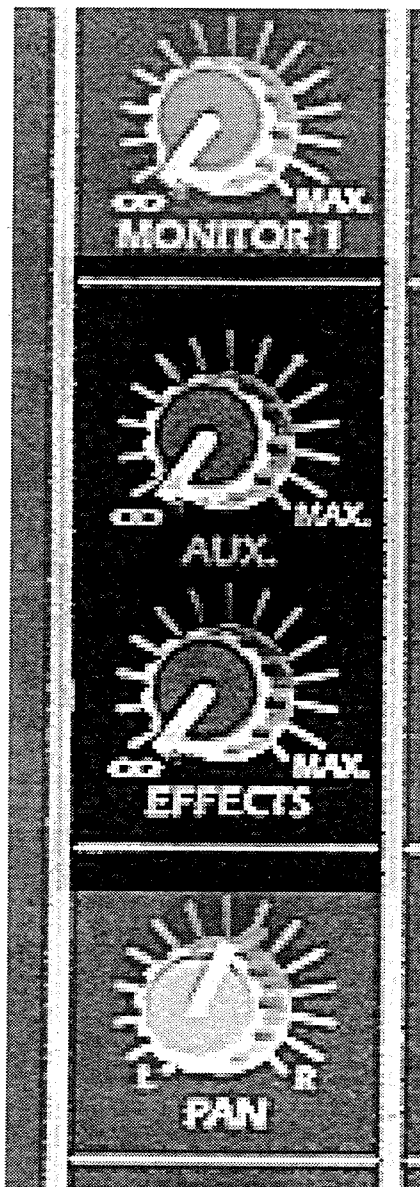

The Effects Mix Controls.

The Input Channel Effects/Reverb send control is post-EQ and post-fader, and is located directly above the input channel pan pot. The effects/reverb mix comes from each input channel, via the effects send control.

What the Effects Mix Does.

The Effects mix operates much like the Monitor mixes; that is, it mixes each Input Channel onto the Effects bus in a similar manner to the way the Input Channel Monitor 1 and 2 controls mix each Input Channel onto the Monitor 1 and 2 buses.

There are a couple of important differences, however. The Effects mix is both post-EQ and post-fader (the Monitor mixes are pre-EQ and pre-fader). This means that when you make changes in the settings of any of the three Input Channel Equalization controls, that action will also change that Input Channel in the Effects mix and, unlike the Monitor mixes, when you change the setting of the Input Channel fader, that action also changes the level of that Input Channel in the Effects mix.

The Effects Mix Master Section.

These signals combine on the effects mix bus are controlled as a group by the effects master level control. The Effects mix has a master level control, but no master fader. The effects master level control is located directly below graphic equalizer "A". A solo switch is also provided, allowing monitoring (via headphones) and output metering of the effects mix.

The Effects Section Patch Bay Output Jacks.

The output of the effects mix finally comes out of the mixer on a jack in the patch bay (effects out).

The signal that appears on the effects out jack is also hooked-up through "normalled" switch contacts, into the reverb input jack (REV. IN).

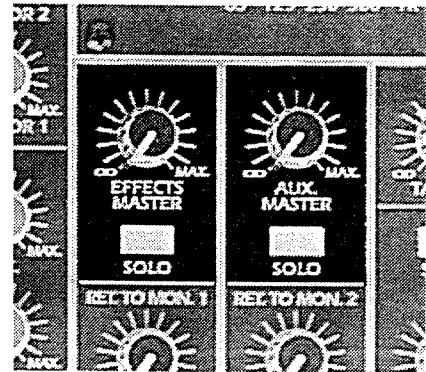

If a cable is plugged into the REV. IN jack, the "normalled" signal (the effects mix) is interrupted, and the Internal Reverb is automatically disconnected.

Whatever signal is plugged into the REV. IN jack is then routed to the DSP reverb/effects system.

The Built In Reverb/Effects Section Of The PX-2200.

From the REV. IN jack, the signal is fed to the internal digital (or, in the case of the PX-2208, the spring) reverb and effects circuitry. The built in reverb and effects section in the PX-2200 has a mono input, but also has a true stereo output. Where reverberation is concerned, a monophonic effects mix is actually better than a true stereo mix. This is because natural reverberant sound from music in a room comes from random acoustic reflections which have no apparent source.

The output of the reverb is true stereo, and is sent to the left and right reverb out jacks (L. REV. OUT and R. REV. OUT jacks), which are in turn "normalled" to the effects return controls, via the effects return left and right input jacks (EFFECTS RET. L and EFFECTS RET. R).

Plugging a cable into either the EFFECTS RET. L or EFFECTS RET. R jack interrupts the "normalled" connection.

If you have bought a PX-2208, the following section on the DSP circuitry will not apply. Instead, you have a unit with a high quality spring reverb. There are no controls to worry about, except for the effects send controls on each input channel, the effects master controls, and the effect return section. These controls operate the same as the DSP equipped units. There are no controls for selecting the "types" of reverb, the delay time (it is fixed on spring units) or a defeat switch.

Before those of you with DSP units gloat, consider this: for certain Guitar sounds, NOTHING beats an old fashioned spring reverb, and the unit inside the PX-2208 is one of the best spring units money can buy! If you want to add digital effects, you can still add on an outboard unit, and use the Aux. sends and returns for the digital effects, while maintaining the spring reverb. The person with the PX-2208 also spent less money than you (so there!). But, and this is a big but, the PX-2208 owner shouldn't gloat either, since the person with the PX-2208D, PX-2212D, or PX-2216D *did* have more money to play conspicuous consumer, and can now also source one of the new Fender® Outboard Tube Reverb Units (which are *the best* sounding spring reverb units ever made), and use that on the Aux. send and returns! They have the best of both worlds. But enough of this tit for tat. Let's move on.

The internal DSP (digital audio signal processing) system of your PX-2208D, PX-2212D, and PX-2216D provides 127 different "types" of reverbs and effects. These are selected via the two blue rotary switch controls, located in the DIGITAL REVERB

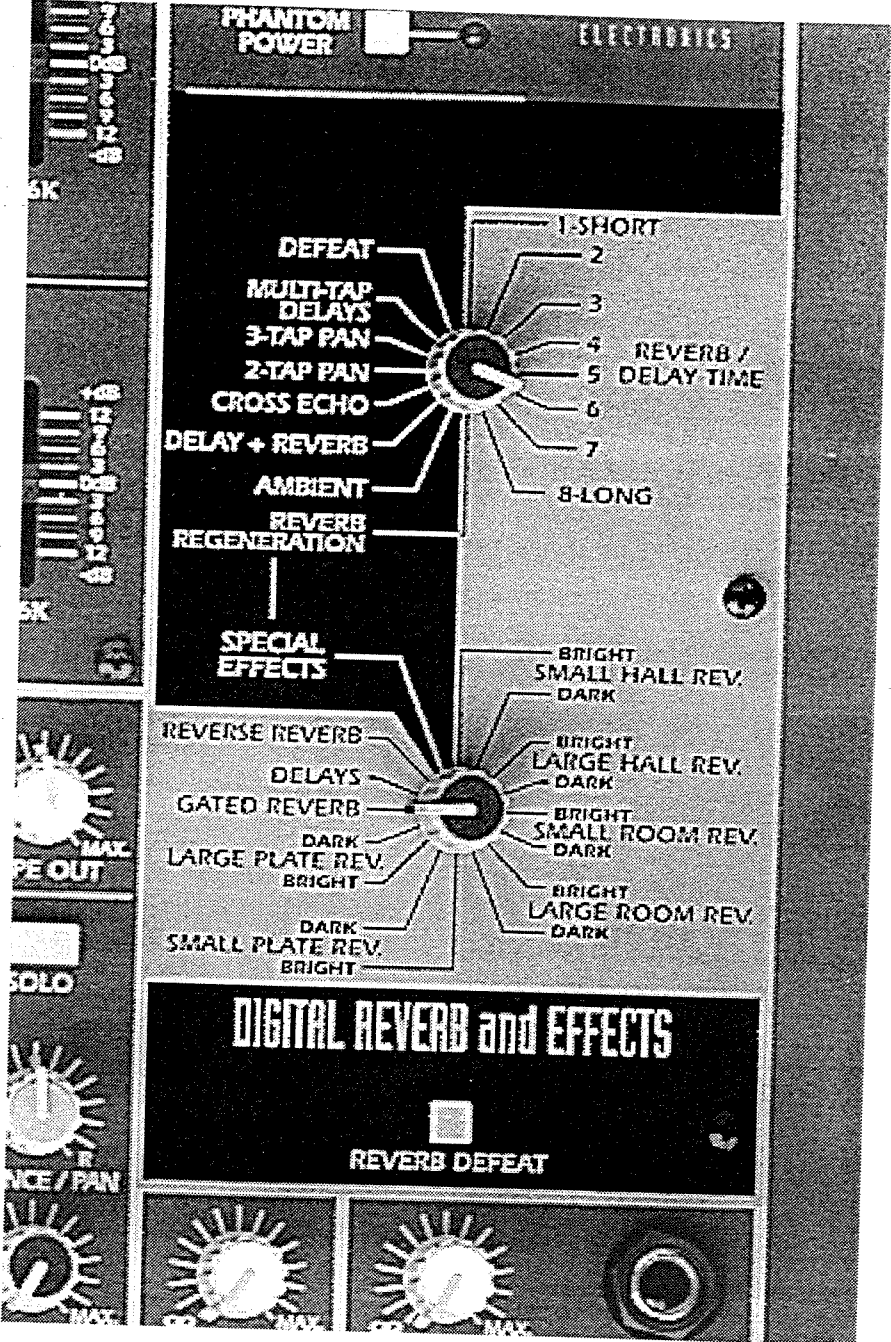

AND EFFECTS section on the right hand side of the mixer, below the red Fender logo.

These two controls work together to select and modify each reverb sound or algorithms. This section is laid out in a way that the top switch can perform two functions. This is indicated by the panel graphics, which show a light colored section, and a dark colored section. If one was to draw a vertical line through the center of the top control, the settings to the

right of the center line would work with the 14 reverb "selections" of the bottom control, which are shown as dark gray text on a light gray background. The top switch settings to the left of the center line work when the bottom switch is set to the SPECIAL EFFECTS setting, shown as light gray text on a dark gray background. These two controls are continuously variable optical encoders, which mean that unlike a regular rotary switch, these can be rotated all the way around, without a stop

position. They are detented to allow the feeling of a switch, to aid in quick selection.

These two switches work in conjunction with ROM (read only memory) circuitry inside the DSP section, and send the control instruction software to the DSP computer chip, thus modifying the sound of the effect chosen. There are 14 reverb "selections", plus a delay setting, that are selected by the bottom rotary switch.

The 14 reverb "selections" are grouped into 8 basic types of reverbs. They emulate most popular acoustic and electro-mechanical reverberators that are used in recording studios (a small hall reverb, large hall reverb, small room reverb, large room reverb, small plate reverb, and large plate reverb).

Of the 8 basic "types" of reverbs, 6 of them can be selected for a bright or dark setting. This selects the high frequencies that pass through the reverb system (also referred to as H.F. damping). In addition to these, there are also two other reverb settings, plus straight delay settings.

The other two reverb settings include reverse reverbs and gated reverbs. In a normal reverb there is the initial (early) reflected sound (at nearly the same level as the direct sound), followed by a long decay "tail" of reverberation, that fades out as the reflected sounds die off. With a reverse reverb effect, the opposite is true. The initial reflected sound is nearly off, but the level increases instead of dying out, up to the limit of the reverb time. This is also sometimes called backwards reverb, since it sounds somewhat like a tape being flipped over and played backwards.

A gated reverb simulates the sound of a reverb chamber followed by a noise gate, set to fade off the reverb "tail" as the direct signal fades, as opposed to hanging on after the direct signal has faded. This allows a dense reverb to occur during the time the direct signal is on, but does not result in a "washy" sound as the reverb trails off.

This effect is very popular on drums (listen to a Phil Collins record), as well as on other instruments and even voices, particularly where a "tight" mix is desired.

Each of the 14 reverb "selections" can be adjusted for a short reverberation decay time, or for a long decay time, using the top rotary switch (in the positions to the right of the center line), which acts as the REVERB/DELAY TIME control. These range from short (position 1 near the top), to long (position 8 near the bottom). Listen to each of these different settings.

When the bottom switch is rotated to the "SPECIAL EFFECTS" position, the top switch should be rotated to the left of the center line. This then selects from seven other special effects. These include:

1) **Defeat.** In this position, the effects section is bypassed.

2) **Multi-Tap Delays.** This simulates a multiple tap (outputs at various delay times) digital delay.

3) **3 Tap Pan.** This simulates an automated pan control, that stops in the left, center, and right positions. Auto-panners are great for having a signal "move" in position during a mix.

4) **2 Tap Pan.** Like 2 above, but only left right (does not stop in the center).

5) **Cross Echo.** This effect puts a delay on the opposite channel from the direct sound.

6) **Delay & Reverb.** This simulates putting a digital delay before a reverb chamber, thus increasing the time it takes for the first early reflection to occur.

7) **Ambient.** This effect is great for simulating stereo out of a mono signal.

8) **Reverb Regeneration.** This has the effect of setting up a low level (not runaway) feedback in the reverb, thus regenerating the delayed signal, and increasing the reverb time dramatically.

At the bottom of the DIGITAL REVERB AND EFFECTS section, is a small push button switch called REVERB DEFEAT. This switch performs the same function as the Defeat position on the top rotary switch. That is, it turns the reverb or effect off, without requiring you to change the send and return level controls. This can be extremely handy, for instance, at the end of the song, when the performer steps up to the mic to thank the audience, and is all of a sudden is greeted by a wash of reverb. If you have carefully set the send and return level controls where you want them for music, this switch allows you to temporarily turn off the reverb, then turn it back on when you go back to music.

Please take the time to carefully listen to each of these effects. You will notice subtle differences that make certain settings more desirable for use on a specific voice or instrument, and a little time spent learning these sounds will pay off incredible creative dividends in the near future.

The Effects Return Section.

Effects returns are actually inputs in the output section. As opposed to your average every day inputs, returns are called to a special purpose. Basically, they provide a way to return outboard effects back to the mixes.

The effects returns act as additional stereo or mono inputs, and allow you to select how much of the reverb signal is routed to the stereo main, and to the two stage monitor mixes.

The EFFECTS RETURN TO MAIN return section provides a stereo level control, a pan/balance pot for positioning on the stereo master left and right buss, a solo switch (to help you isolate and fine tune the reverb settings by listening over the headphones),

The return sections (both effects and aux. returns) can operate in either a true stereo mode, or in a mono mode. In the true stereo mode (where the stereo output of the effects device, both left and right, are plugged into the effects L. In and effects R. IN jacks), the level control acts like a dual control, adjusting both the volume of the left and the right channel, and the pan/balance control acts like a balance control on your Hi-Fi, allowing you to shift the stereo image to the left or to the right. In the mono mode, you can plug the output of your effects device into either the left or the right return jack. In this case, the mono return is fed through the level control, and to the pan/balance pot, which now acts just like the input channel pan control, allowing you to place the return signal anywhere in the stereo spread.

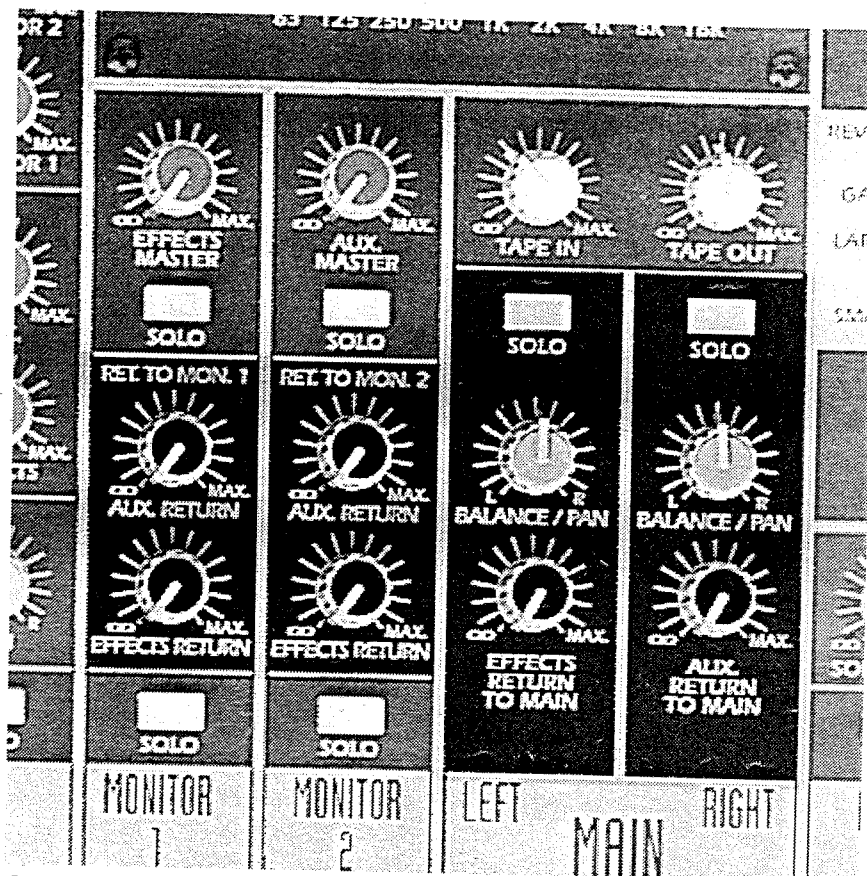

An Exercise: Using The DSP Reverb And Effects.

If you haven't already done so, read "The Exercises". For this session, we'll use the Internal DSP Reverb, but you can repeat this session with an external effects device if you wish.

Play a tape of a group (an "uncluttered" tape with the least possible amount of reverb and effects) and set the Input Channel faders and the Master Left and Right faders for a comfortable listening level. Bring up the Channel 1 Effect control about half way. Look at the digital reverb and effects section of the mixer. For starters, make sure the REVERB DEFEAT switch is NOT pushed in. This switch is used for turning off the reverb in between songs, when someone is speaking. Rotate the bottom reverb selector switch, until it is in the LARGE PLATE REVERB-BRIGHT setting.

Turn the control above it to the right, until the REVERB/DELAY TIME control is in the 8-LONG position.

Slowly bring up the EFFECTS RETURN TO MAIN control, and center the BALANCE/PAN pot located directly above the effects return control. Wow! Reverb! Try moving the Effect Return Balance/Pan control from "L" to "R", and the reverberation will move from your Left loudspeaker to your Right Loudspeaker.

Bring up the Effect send control on Channel 2 and you'll notice a subtle change. When you only had effects on Channel 1, only those instruments and voices coming into Channel 1 had any reverberation added to them. Now, with both Effect controls up, you have added reverberation to the instruments and voices on both Channel 1 and Channel 2.

Now, for another subtle effect, turn down both Effect controls on the Input Channels. Pan input channel 1 fully left and input channel 2 fully right, so that you have the direct signal coming from your loudspeakers in true stereo.

Center the Effect Return Pan control, and place the Effect Return Master control about half way up. Now, bring up the Channel 1 and 2 Effects send controls until you hear reverberation in your loudspeakers. The reverberation is a mix of the "reverberated" signals from both Channel 1 and Channel 2.

The signal going to the reverb is mono (from combining the input channel 1 & 2 effects sends), but the output of the DSP section is stereo, putting different "reflections" of the reverberated sound into the left and right channels. Turn the Effect Return Pan control from left to right. This places the reverberation in either the Left or the Right loudspeaker.

Play with the effects settings, selecting different types of reverbs, with dark and bright voicings, and vary the delay time. Your mind should be whirling with a vortex of possibilities.....

There are two more controls in the Effect Return cluster you should try out. These two controls; "EFFECTS RETURN TO MONITOR 1" and "EFFECTS RETURN TO MONITOR 2", combine the stereo effects return signal into a single mono source (while not affecting the stereo return to the main left and right busses) and allow you to return this mono effects signal into the stage monitor mixes. If you'd like to experiment with these controls, set up your system the way you did when we first discussed the use of the Monitor mixes.

Then, try mixing some reverberation into Monitor 1 and Monitor 2 using the Effect Return Monitor 1 and Effect Return Monitor 2 controls.

The individual input channel effects sends and the effects master controls work just like they do when using the stereo effects return to the left and right main bus. In a live performance, you might do this when you are using one of the Monitor mixes to feed a system in a separate room or, more likely, if you are mixing monitors for a performer who asks for "a little reverb in my monitor".

Using The Effects Send With An Outboard Processor.

It's easy to connect an external effects device in place of the built in DSP section. However, since the DSP section built into the PX-2200 is of exceptional quality, you will probably not want to do this. If you must, however, just connect the device input to the EFFECTS OUT jack and the device output to the EFFECTS RET. L. and EFFECTS RET. R. jack. This automatically disconnects the internal DSP Reverb in your PX-2200 Mixer, replacing it with the external effects device. The internal DSP section can now be patched into an input channel, or whatever other source you may desire.

The Aux. Send.

The AUX. (short for auxiliary) send and returns, works just like the EFFECTS send and returns, with one minor exception. There is no built-in internal DSP reverb/effects processor between the send and the return controls. The AUX. mix is intended to allow you to add a second outboard effects unit, or to use it as a general purpose post-fader auxiliary mix. It can also be used for an extra stage monitor mix, should you desire one. The AUX. send, like the EFFECTS send, is post-EQ/post-fader.

However, it may be modified to pre-EQ/pre-fader operation by a qualified service tech if desired. The AUX. RETURN TO MAIN level control, pan/balance control, solo control, aux. return to monitor 1, and aux. return to monitor 2 controls work just like their EFFECTS counterparts.

Using True Stereo Effects Sends & Returns.

If, for some reason, you need a true stereo effects mix (discrete left and right sends, plus left and right returns), you can use the EFFECTS send, and the AUX. send mixes, with a true stereo (stereo L&R in, stereo L&R out) external effects device, and bring the outputs of these effects devices back in through either the Effects returns or the Aux. returns. Since each return is true stereo, both returns are not needed, unlike the send controls. By using the stereo effects return to bring back a true stereo return from an external effects device (using both the effects and aux. sends), the Aux. Return can then be used as a stereo input channel (for keyboards, tape machines, etc.) if desired.

The Output Section.

While the mixer input channel module may be the most impressive element of a mixing console (if for no other reason than its incredible repetition), its main task is to direct the signal to the business end of the mixer—the output section.

The main mixes that feed power amplifiers or recorders, the monitor mixes that supply signal to stage monitors, and the effects or auxiliary mixes that are sent to outboard signal processors, are all routed through the output section. It is here that you find effects returns, monitoring and metering, communications, and other functions.

The Return of the Magic Bus.

After each of the signals from the input modules have been sent to their chosen buses, each bus connects to its own **output channel**.

Every output channel represents a different mix that has been routed along its own particular bus. As with the input modules, each output channel consists of several different elements:

The Summing Amplifier.

The summing amplifier is the first stop on the output channel. The purpose of the summing amp is to combine (that is, to sum) all the signals on an individual bus into one mixed signal, and isolate them from impedance changes that can occur when signals are added to the bus.

The Master Level Controls.

Next, the master level control is used to adjust the output level of the signal from the summing amp.

Note: As input signals are added to a mixing bus, the overall signal level is increased, generally necessitating an overall reduction of signal level at the output. If you find that you're "bottoming out" the master level control in order to obtain a more reasonable output level, you should go back and reduce the levels on each of the input channels feeding the mixing bus. Both slide faders and rotary knobs are commonly used as master level controls.

Line Amplifiers.

The line amplifier is the next step following the master fader. The purpose of the line amplifier is to send the signal out to the world. To accomplish this, the line amplifier output, which is typically designed to drive a low impedance load, is sent to the output connectors on the mixer.

As with the mixer input channel, the basic design of the output channel is repeated over and over again in the mixer output section, each output tied to a different buss. The number of output channels that are available, and the terms used to describe them, depend on the intended use for each mix that has been created. On the PX-2200, this would include:

The Left & Right Main Output.

This stereo output from the mixer is generally used to drive the power amps in a stereo sound system.

The master level controls for the left and right main are the two white colored slide faders.

The Mono Sum Output.

This is a combination of the left and right main output, summing them together. The mono main output uses a slide fader.

Sub masters.

If the PX-2200 is used as a mono sound system, the stereo left and right main busses may be used as sub masters, and the mono sum as the master. Sub masters are used for many different, and quite useful, functions.

One of the most valuable functions of sub masters is to allow for the creation of audio subgroups that can be simultaneously adjusted from a single sub master control.

Audio subgroups are created by using the pan pot to send the chosen signals to a selected sub master (left or right) output channel.

Once this has been done, a sound engineer can make adjustments in the level of the entire group from one sub master control.

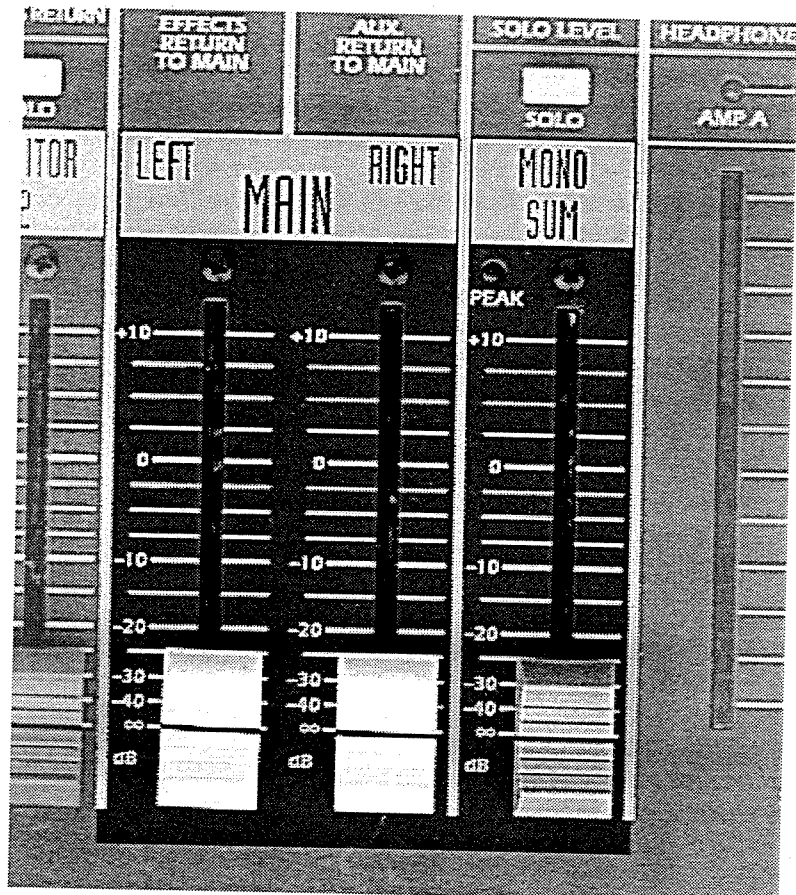

Since few of us have been blessed with seventeen hands, this can be very helpful when dealing with large mixes, both in live sound and recording situations.

Sub-masters can be also used to provide multiple feeds in live sound and broadcast situations. In a recording studio, sub-masters can be used to route a signal to the inputs of a multi-track recorder.



Auxiliary Send Master(s).

Monitor, Effects, and Aux. are some of the labels you're likely to find on these master level controls. The names chosen for these channels will coincide with the names given to them on the input module. Their function is to provide alternative mixes for stage monitoring, outboard effects, or anything else you might want to send a separate signal to. You'll find both sliders (monitor 1 & 2) and rotary controls (Effects and Aux.) used for these master controls.

Monitoring & Metering.

Since the basic configuration of any mixer is designed to allow for simultaneous multiple mixes, it's important to be able to check what is going on at any given point. The output section provides several options (both visual and aural) to accomplish this.

VU Meters.

VU Meters have been around since the early days of audio. Whether they be in the form of a mechanical meter with a swinging needle, an LED bargraph display (as used in the PX-2200), an LCD display, or a graph on a video monitor, the purpose of a VU (VU stands for volume units) is the same.

Sometimes you need more than your ears to understand what's going on with a mix. VU meters provide an invaluable visual reference to supplement what your ears hear.

On the PX-2200, a bar graph LED meter is used (LED stands for a light emitting diode, which is a solid state lamp that will never burn out). In addition to just showing the average output level, the LED bargraph on the PX-2200 also indicates momentary signal peaks by holding the highest point for a brief period of time.

Our natural hearing tends to average out the sounds the ear is bombarded with, and an averaging VU meter operates in the same way.

As we've mentioned before, in a normal sound program there will generally be some very loud peaks (rim shots, the sharp strike of a piano, etc.), yet the overall level may remain fairly low. In other words, if the average level of a program increases, the program sounds louder. If, on the other hand, the peak levels in the program increase, but the average level stays the same, the apparent loudness (to our ears) will probably not increase. These sounds can have a very high peak level and still not sound very loud.

An averaging meter will smooth out these peaks and blend them with the rest of the sound program.

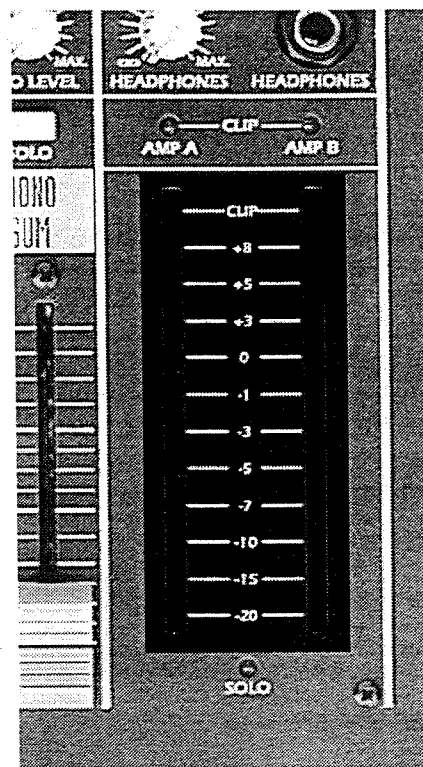

This gives the engineer an indication of the overall signal level (similar to what the ear will hear), but no real indication of the level of these transient peaks. The peak hold function of the PX-2200's meters however, show the maximum level the system is having to provide at any time.

The 0 or "Nominal" Position.

When using either an averaging or a peak reading meter, the best engineering approach is to adjust the signal levels of the mix so that the metering indicator floats somewhere near the nominal point (the 0 reference on the face of the meter). As a rule of thumb, it's okay for the needles (or lights) to temporarily register above the 0 reference point, but they shouldn't stay there! Remember, an averaging meter is showing you the average level of the program, and if it's staying too long (or too often) above the nominal reference point, you're probably overdriving something.

Additionally, while any musical program is likely to have some loud transients that will light the Peak LEDs, if the light is burning steadily, it means something is probably wrong.

On the PX-2200, the top LED of the 12 segment bargraph meters (labeled clip) only lights if you are about to clip the output of the mixer. This may or may not mean that you are driving the power amplifier into clipping.

To see if the amplifier is limiting itself (using the built in DeltaComp™ circuitry), check the two small round red LED's just above the bargraph meter, "CLIP". If the one labeled "AMP A" is lit, the signal feeding amplifier A is causing it to clip.

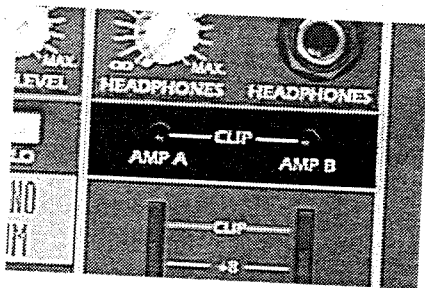

To determine which output you need to turn down, look at the assignment switch on graphic equalizer A, which also selects the feed to the power amp (providing that nothing is plugged into the graphic eq. in/out jacks, or the Amp A In jack on the patch bay). If the "AMP B" clip LED is lit, turn down its source (master), as selected by the assignment switch near graphic equalizer B.

The VU Meters on your PX-2200 Mixer read "0" when the signal level at the mixing console output jacks is +0 dB. The signal level at those jacks may rise to as high as +22 dB, however, before clipping occurs. The power amplifier in your PX-2200 will begin to limit itself way before that however.

There is a full 22 dB of "headroom" at the mixer output jacks, when to meter is at it's nominal position of "0".

This +0 dB output level, along with its full 22 dB of headroom, allows your PX-2200 Mixer to be compatible with a vast array of auxiliary audio devices designed for these levels, such as: tape recorders, limiters, equalizers, special effects devices and so on. When you connect one of these auxiliary devices (with either a 0 dB nominal input level) to the mixer main Out jacks, the "0" position on your PX-2200 Mixer's VU Meters becomes the nominal position. If the device's nominal input is +4 dBm or dBu, the nominal 0 position on the mixers LED meters would be slightly above the +3 dB LED.

Some auxiliary devices, like consumer audio recorders, and some low-cost multi-track tape recorders, are designed for a nominal input level that is below the 0 dBu output level of your PX-2200 Mixer. A -10 dB input level is common on these machines. In order to match levels properly, the "nominal" position on your PX-2200 Mixer's VU Meters must be about 12 dB lower (between the -10 and the -15 LED on the VU meter). Alternatively, to keep the "0" position as the nominal position, you could insert a 10 to 12 dB pad between the Pre Amp Out jack and the input of the -10 dBV tape machine (See "Pads and Transformers).

Most professional power amplifiers are designed to produce their full output power when they receive an input signal of between 0 dB and +8 dB. The two power amplifiers inside your PX-2200 reach their full output of 150 watts (PX-2208 & PX-2208D) and 300 watts (PX-2212D & PX-2216D) into 4-ohms when they receive a +4 dB signal (at the Power Amp In jacks).

That means that the +4 dB Input level is the maximum (not the nominal) input level to the Power Amp In jacks. Above +4 coming out of the mixer, the Delta Comp circuitry will begin to limit the input to the power amplifier. Remember that the +0 dB output level of the Pre Amp Out jacks is not their maximum but their nominal output level (The maximum output level from the Mixer Output jacks is +22 dB). In order to have 10dB of headroom in the power amplifier (before you begin to limit via Delta-Comp), the nominal output would have to be -6 dB (between the -5 and -7 LEDs), not 0 dB.

This may seem a bit confusing at first, but it does allow your PX-2200 to be compatible with an extremely wide range of pro and semi-pro audio equipment. It is also an audio industry standard to publish the maximum input level to a power amplifier and the nominal output level of a preamplifier/mixer (or other low level or line level device)!

The reason for this difference is that you will commonly insert several auxiliary devices between the output of a mixer and the input of a power amplifier. Some of these auxiliary devices may cause a loss in level of up to 10 dB or more. This loss can be overcome, however, by the additional output level available from the mixer. Your PX-2200 Mixer's main Left & Right output jacks have a maximum output of +22 dB for exactly this reason. You can insert auxiliary devices having as much as 18 dB of loss (a passive graphic equalizer, for example) and still have enough output level to drive the internal power amplifiers to full output (Almost all professional unpowered mixers are designed this way, although most powered mixers are not).

When you are not using any auxiliary devices, however, the main Left & Right Output jacks are capable of 18 dB more output level than needed to drive the Power Amp to full power. This means that the nominal "0" VU Meter position must be lowered to -6 dB on the face of the VU Meter. Alternately, to keep the "0" position as the "nominal" position on the VU Meters, you can insert a 6 dB pad between the Pre Amp Out jacks and the GEQ out and the Power Amp In jacks. (See "Pads and Transformers").

Using the VU Meters.

In general, it's a good idea to keep the VU Meter swinging around the nominal position or below (The nominal position may change, of course, as explained in the previous section). Occasional swings above nominal are acceptable, but frequent swings above nominal probably means that you are overdriving any auxiliary equipment connected to the main Left & Right Out jacks (or you may be overdriving your PX-2200 Mixer's internal power amplifiers which will cause the Clip LED to light). When this happens, you may experience the kind of distortion known as clipping, which you will hear as a very raspy, irritating sound quality.

The VU Meters give you an idea of the loudness (the average power level) of the signal. While the VU Meter shows average power level, the VU Meter Peak LED indicates the presence of high-level (but normal) program peaks and the Clip LED indicates the presence of very high level (undesirable) program peaks. In addition, unlike the purposely slow response of the VU Meters, the VU Meter Peak and Clip LEDs respond very fast. This means that the VU Meter Peak LED may turn on occasionally even when the VU Meter is at or below its nominal position.

As long as you don't hear any distortion, it's probably okay for the Clip LED to light occasionally. If the Clip LED begins to light frequently or stays on longer than an instant, turn down the level! Power levels high enough to cause this kind of sustained clipping will not only produce severe distortion, they may harm your loudspeakers.

Severe clipping distortion is one of the most common causes of loudspeaker damage. In fact, the clipping distortion produced by overdriving a small power amplifier can actually be more dangerous to a loudspeaker than a higher level of unclipped power from a larger power amplifier.

Using The VU Meters: An Exercise.

If you haven't already done so, read "The Exercises." Then, play a tape through Input Channels 1 and 2. As you mix the Channel 1 and 2 inputs to the Program Left and Right outputs, watch the VU meters. The VU Meter Peak LEDs will light occasionally on normal program peaks; their operation is similar to the Input Channel Peak LEDs.

The Clip LEDs should not come on (except very rarely) during normal operation.

The indicators on your Fender PX-2200 Mixer can do a lot more than just tell you whether or not a signal is present and how loud it is (or whether it's too loud). For example, you're mixing an unfamiliar singing group of all female voices. One voice stands out and needs to be lowered in level, but which one is it?

With a little practice, you can tell from how often the Peak LED is lighting. The Peak LED will light more often, and stay on longer, on the channel with the loudest signal (the stand-out voice).

As another example, imagine that the audience is arriving and you still haven't managed to get a full sound check (no matter how well you plan . . .). You know the performance, but are all the mics working?

You don't want to disturb the audience by having "Check, One, Two!" coming through the loudspeakers, so you simply turn down all your faders and have a helper talk into the microphones one by one while you watch the Signal LEDs on each channel! If all the Signal LEDs come on at the appropriate mic check, you are reasonably assured that these Input Channels will work properly when your performance starts. There are, of course, other things that could cause the Signal LEDs to light—like bad cables for example, but we'll cover that in the section on Troubleshooting, near the end of this Manual.

As a final example, assume that you've been cooped up in an enclosed room (perhaps with the lighting crew) and told to mix a performance. This, of course, is an extremely undesirable situation, because you can't hear what the audience hears and your ability to do your job well has been dramatically impaired! How do you mix the performance? By listening to the system (using a tape) before the performance to get an idea of how loud it will be for a given VU Meter reading. Then, during the performance, you can watch the VU Meters and have a reasonable idea of the actual loudness in the audience. Even watching the VU Meters closely, however, and even if you have a good set of control room monitor loudspeakers, it's still a good idea to move out into the audience area as often as possible to get a "live" viewpoint of the sound.

In brief review then, the Input Channel "Peak" LED indicates the presence of a high-level input signal. Don't confuse the Input Channel Peak LED with the Power Amplifier Clip LED.

The Power Amplifier Clip LEDs light when the output signal is so high that it is actually causing clipping distortion in the power amplifier. The VU Bargraph Meter red peak LED functions much like the Input Channel Peak LED, except that the VU Meter Peak LED indicates the presence of high-level peak signals in one of the output channels.

It is normal (and even desirable) for either the input channel Peak LEDs or the red bargraph VU meter LED's to light occasionally, even frequently (but not stay on continuously). However, it is definitely not desirable for the amplifier Clip LED to light frequently and highly undesirable for the Clip LED to stay on for any length of time (it is okay for it to light infrequently for an instant).

The VU Meter shows a continuously varying display of output signal level in a way that approximates the way we hear. Thus, the VU readings are a good indication of the apparent loudness of the signal level.

Again: the green signal LEDs on the VU bargraph meters means low-level signal (it will stay on when signal level gets higher), yellow means pay attention; and the red "Peak" means high-level peak signals (Peak can light frequently but not continuously). Clip means the signal level is too high and is causing distortion (it's okay for Clip to light infrequently). The VU Meters show average signal levels, which corresponds to apparent loudness. Keep the VU Meters swinging at or below the nominal "0" position (it's okay to allow them to swing above nominal on occasion).

The Two Switchable Master Graphic Equalizers.

The Master and Monitor Graphic Equalizers appear in the block diagram before the Master or Monitor faders. That is, they are pre-fader. In the Master Output Channels: the Line Out jacks are "normalled" (normally connected) to the G-EQ IN jacks. Connecting an external device to the G-EQ IN jack automatically disconnects this normalled connection.

An Introduction to the Master Graphic Equalizers.

The two main graphic equalizers perform tone control like functions for the master outputs in a similar manner to the way the Low, Mid, and High controls work on the Input Channels. There are, however, two important differences: First, the two master equalizers are graphic equalizers (graphic equalizers are discussed in detail in the section entitled Using The Graphic Equalizers).

This means that there are more controls, each control affects a narrower frequency range (it's like having three Low, three Mid, and three High controls, each at a separate frequency), and because the controls are slide faders, you get a graphic representation of the EQ curve.

Second, the master graphic equalizers affect an entire mix. That is, the master Left Equalizer affects the frequency response (and therefore the sound quality) of every input that is panned to the left mix bus.

Because they operate on individual Input Channels, you will normally use the Input Channel Equalization controls to affect the tonal character of an individual source (a microphone or instrument pickup, connected to one of the Input Channels).

Because they operate on an entire mix (an entire main, mono, or monitor output channel), you will normally use the master graphic Equalizers to affect the tonal character (the frequency response) of one of the outputs used in your system. That is, the master Graphic Equalizers are used to "EQ the system", be it the main (front of house) p.a., or the stage monitor system(s).

An Exercise: Using The Graphic Equalizers.

If you haven't already done so, read "The Exercises". Then play a tape or CD of a group of instruments and/or voices. Experiment with the sound quality changes you get when you boost or cut the various sections of the master Left and Right Graphic Equalizers. Notice that each control causes similar effects to those you experienced when using the Input Channel Low, Mid, and High controls. The Program Graphic Equalizer controls, however, affect a narrower frequency band. You can hear that by first trying the Input Channel Low control, (then set it back to its center position) and then trying the Master Graphic Equalizer "125" control (which means 125 Hz). Experiment with the other controls, comparing them to the Input Channel controls if you wish.

Because they affect an entire mix, you wouldn't use the Master Equalizers to try to enhance the "presence" of a lead singer's voice because your actions would affect everything else in the Master mixes! You might, however, use the Master Equalizers to enhance the presence of the entire sound system in a "dull" sounding room full of carpeting, draperies, and over-stuffed furniture (some hotel lounges are like this). In other words, use the Input Channel Low, Mid, and High Equalization controls when you need to affect an individual instrument or voice.

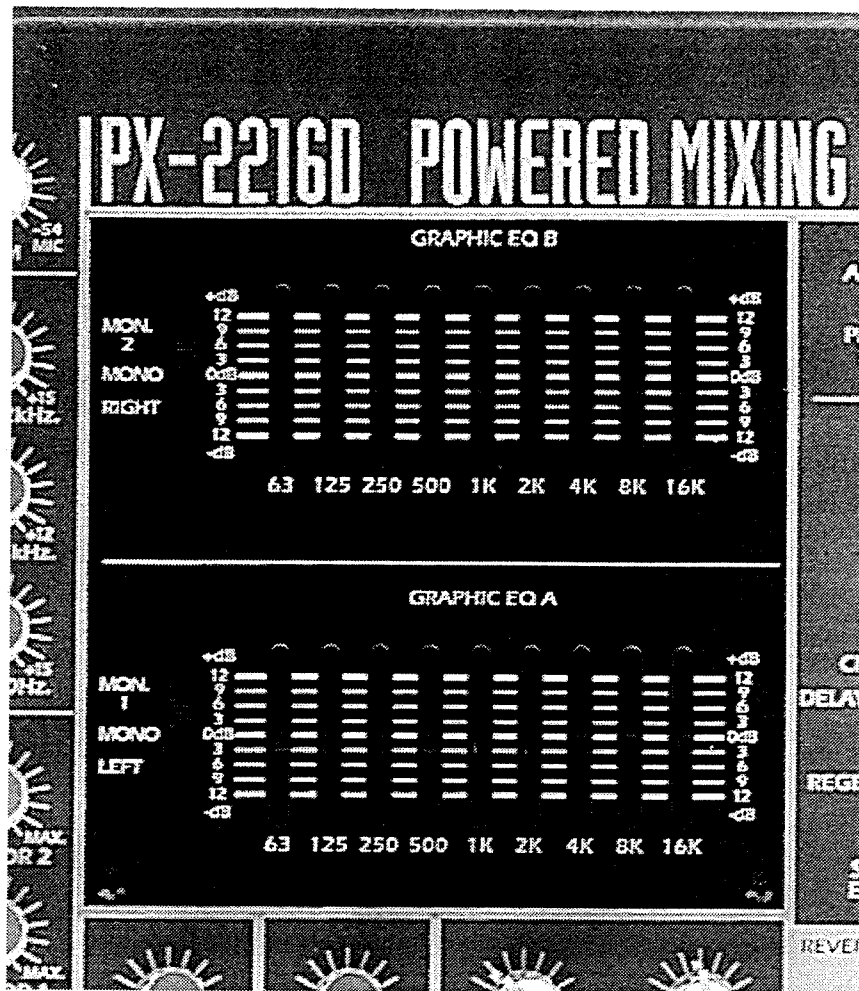

Use the Master Graphic Equalizers when you need to alter the sound quality of an entire mix (or your entire sound system).

Like the Input Channel Equalization controls, the Master Graphic Equalizers are powerful tools. And, like the Input Channel controls, the Master Equalizers can enhance a performance, or detract from it. Remember that, in almost every case, 3 dB to 6 dB of boost or cut on any individual control should be sufficient. Don't hesitate to use the Master Equalizers, as much as you need them (that's why we put them there!). But think of them as artist's tools, and use them with an artist's touch!

Headphones.

While the metering circuits give you an invaluable visual reference

point, it's important to have the ability to hear what's going on as well (after all, we are talking about sound). The headphone circuit allows you to monitor (with headphones coincidentally) a variety of mixes by selecting them with the **solo** button. Generally, you have the capability of monitoring any output channel (as well as any input channel selected with Solo) on the headphones. If the channel(s) you wish to monitor are stereo (as with the left and right main) the signal will be heard in stereo on the headphones. If it is a mono signal (as with effects sends, sub-masters, etc.) the signal will be heard in mono over both channels of the headphones. One of the big advantages to headphone monitoring is that it allows you to hear separate mixes (such as the stage monitor mix) that you would otherwise not be able to hear.

On the PX-2200, the headphone level control and headphone jack are located directly above the bargraph meters and amplifier clip LEDs.

Program and Monitor Graphic Equalizers

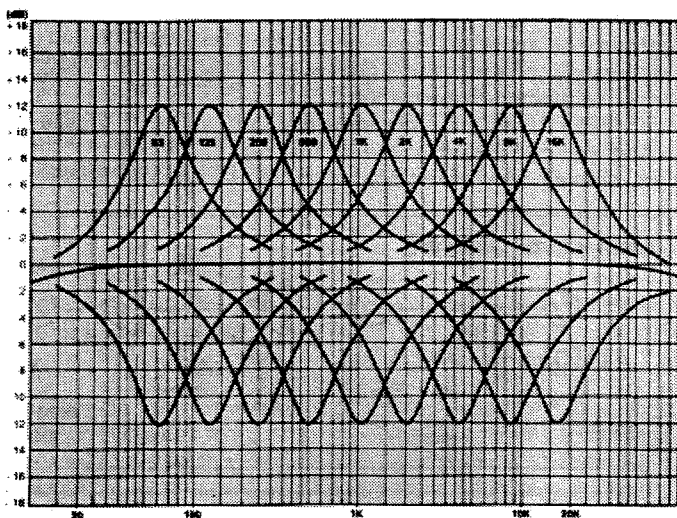

Solo Level.

As we mentioned when examining the solo function, the Solo switches on the PX-2200 provide the advantage of monitoring what's going on with an individual channel without altering the main mix. It is in the monitor section (on the headphone and/or meters) that this solo monitoring is accomplished. Activating any of the solo switches will override the left and right main in the monitoring circuits, and send a solo signal from the selected channels instead.



In order to allow the engineer to match the solo level in the headphones to a comfortable monitoring level, the Solo level control is provided. Without this control, the solo level may be too high or too low in the headphones, requiring constant adjustment of the headphone level control.

This is due to the fact that the PFL solo, being prefader, may be far hotter than the other signals that have been combined onto the mix buss via the faders and pan pots.

Tape In Level Control & Tape Playback Jacks.

The two tape playback RCA phono jacks located on the patch bay of the PX-2200 are routed to the stereo tape playback level control. This control is located directly below graphic equalizer A, in the master section. This control acts as a stereo line-level return, directly to the stereo mix, allowing you to playback a stereo tape or CD without tying up an input channel.

Tape Out Level Control & Tape Record Out Jacks.

The two tape record RCA phono jacks located on the patch bay of the PX-2200 are intended to feed the inputs of a stereo cassette deck or DAT recorder. They take their signal from the stereo main left and right buss, but their pick off point is PRE the stereo main left and right master faders. This allows you to set a totally independent stereo record level off of the stereo mix buss, without having to worry about changing levels due to the requirements of the P.A. system. This is handy for running a tape of the evenings performance. In addition, if you use the left and right mix busses as sub-masters in a mono p.a. system, it allows you to still make a recording. Even if the masters are turned all the way off, you will have level (provided the tape out control is turned up).

If you wish to make a recording that captures all of your master fades, you can also take the left and right main outputs, and feed that signal into the inputs of your recorder. This will not interrupt the signal fed to the EQ selector switch, and to the graphic EQ's and power amplifiers. Plugging into either the GEQ in, GEQ Out, or Power Amp in jacks will however, interrupt the signal.

Power Amplifiers.

Power amplifiers amplify power, and ideally they accomplish this rather singular purpose with little or no interference to the basic nature of the signal.

Amplifier Basics.

We have said that the function of an audio amplifier is to increase the power of the audio signal.

What precisely does that mean? What precisely does it do?

The basic principle of an audio power amp is that a large amount of available power (i.e., the 60 Hz



AC of a typical power line, converted into DC through the power amplifier power supply circuitry) is modulated by the weak audio signal fed from the mixer. The weak audio signal is thereby converted into a much stronger signal which drives a set of loudspeakers, transforming the sound wave pattern of the power amp signal back into an acoustic replication of the original sound wave (only a lot louder). The crucial issue in evaluating the quality and effectiveness of a given amplifier is how well, and over how wide a frequency range (bandwidth), does it perform this modulation, while maintaining the basic integrity of the signal.

Dual Channel Power Amplifiers.

Professional amplifiers are not the fancy faced, gadget laden audio shelf art that most people think of

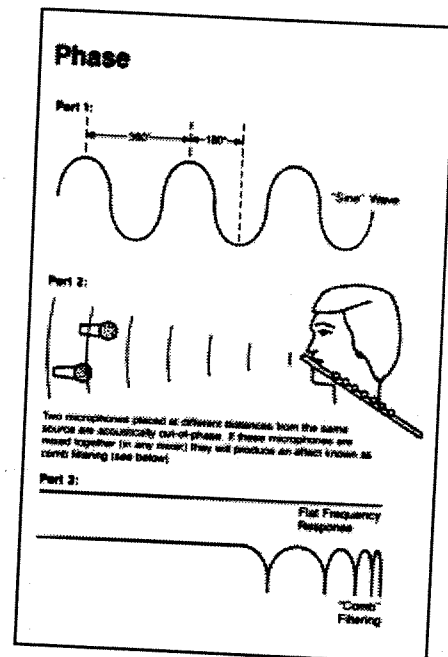

when they picture a typical home stereo "receiver", but rather plain and powerful workhorses that do the "muscle" work of sound reinforcement. Generally, professional power amplifiers have line level inputs, and high level outputs, and (usually) a power switch.

Amplifiers And Loudspeakers.

A power amplifier has one purpose: to provide a usable signal to the loudspeaker(s). Because of this, there is a very real sense in which amplifiers and loudspeakers function as a single unit, and it is important to understand the ways in which loudspeaker performance affects amplifier performance, and vice versa.

Impedance Concerns.

Loudspeaker impedance is a measure of *how much opposition the loudspeaker provides to the flow of AC current from an amplifier to which it is connected. The lower the impedance, the more power the loudspeaker will draw at a specific signal voltage.*

Because of this interaction between loudspeaker impedance and amplifier power, most equipment manufacturers provide amplifier power ratings for at least two specific load impedances.

The minimum load impedance on most amplifier specs will be 4 ohms, though some may state a load impedance of 2 ohms. It's usually not a good idea to have less than a 4 ohm load impedance in a professional sound situation. Smaller load impedances put undo stress and strain on your amplifier(s).

Impedance involves both resistance and reactance. Reactance is frequency based (meaning its value changes as the frequency changes), and subsequently the impedance rating is also frequency based.

Loudspeaker specs will generally provide a "nominal impedance" given in ohms, but this figure will vary widely during actual operation. The most helpful type of impedance specification is a graph of the **Loudspeaker Impedance Curve**, in which impedance is plotted against frequency. Like other graphically presented specifications, such information gives you a much better picture of what to actually expect when you employ that loudspeaker in an actual concert situation.

Converting Amplifier Power to SPL.

This incredible increase of available power is pointless if it isn't ultimately converted by a loudspeaker into sound pressure waves that impact the ear drum of the listener. The **sensitivity** of a loudspeaker is the factor that relates this amplifier power to SPL. The sensitivity of a loudspeaker is a measure of its responsiveness to an audio signal. Generally specified in dB SPL, loudspeaker sensitivity is measured on axis (directly in front of the loudspeaker) at 1 meter away when 1 watt of power is fed to the loudspeaker.

Admittedly, NO ONE listens to concert loudspeakers at one meter in front of them, but it does give us a standard of measurement that everyone agrees on.

Loudspeakers, on the other hand, are often connected in parallel and sometimes connected in series. Connecting loudspeakers in series will degrade their performance somewhat (it lowers the "damping factor" and thus degrades transient response), but connecting them in parallel will cause no degradation at all, provided the power amplifier is not overloaded.

The only way you can know whether or not the power amp is overloaded, of course, is to calculate the total impedance connected to it. Here's how:

Series Impedance Calculations.

Series impedances (see diagram) are easy. You just add them up. Thus, two 4-ohm loudspeakers connected in series result in a total impedance of 8-ohms. Three 16-ohm loudspeakers connected in series results in a total impedance of 48-ohms.

Parallel Impedance Calculations.

Parallel impedance's combine according to this formula:

$$\text{Formula 1: Total Impedance} = \frac{1}{1}$$

$$\frac{1}{(1/Z_1 + 1/Z_2 + 1/Z_3 + \dots + 1/Z_N)}$$

Where Z_1 is the first impedance, and Z_N is the "nth" or last impedance.

This formula works on any group of parallel impedances, even if they are different values. Fortunately, it's a lot easier if there are only two impedances. Then the formula reduces to this next one:

$$\text{Formula 2: Total Impedance (Two Impedances in Parallel)} = (Z_1 * Z_2) / (Z_1 + Z_2)$$

This formula, like the previous one, works even if the two impedances are of different values. The most common situation, in audio however, is even easier. When we parallel two or more loudspeakers which all have the same impedance, the total impedance is just the impedance of one loudspeaker divided by the number of loudspeakers in parallel.

In other words, paralleling two, 8-ohm loudspeakers results in a 4-ohm total impedance.

Paralleling two 16-ohm loudspeakers results in an 8 ohm impedance. Paralleling three, 8-ohm loudspeakers results in a 2.67-ohm total impedance (8 divided by 3).

Series/Parallel Calculations.

Occasionally, we connect a set of loudspeakers in "series/parallel". To get the total impedance in the first series/parallel diagram, you calculate the impedance of each series group (just add them) and then combine those groups in parallel (by using one of the parallel formulas above). To get the total impedance in the second series/parallel diagram, you calculate the impedance of each parallel group, and then combine these groups in series. In each case, you break down the connection into groups, calculate the impedance of each group, and then treat each group as if it were a single impedance.

The most common use of series/paralleling in audio is to take a group of 4 loudspeakers (all having the same impedance) and connect them in series/parallel.

The resulting impedance is exactly the same as a single loudspeaker. Four, 8-ohm loudspeakers in series/parallel, for example, results in a total impedance of 8 ohms.

Impedance and Power Transfer Again.

We discussed impedance and power transfer in the section entitled "Some Notes on the Power Amplifiers". But it's worth reviewing here what happens to the power output of an amplifier, when you connect different impedances to it. You have to know the rated power output of the amplifier and its rated load impedance.

That rated load impedance, of course, will often be the amplifier's minimum acceptable load impedance. In addition, you should know the loudspeaker's true minimum impedance as well as its rated or nominal impedance.

Normally, you will use the loudspeaker's nominal impedance to make impedance "watching" calculations like those described in the next paragraph. A loudspeaker's minimum impedance, however, can fall significantly below its nominal impedance, and a loudspeaker with an extremely low minimum impedance could overload your power amplifier. The power amplifiers in your PX-2200 Series Mixer are designed to accept impedances as low as 2 ohms, because of the very low minimum impedance of some loudspeakers. Many 8-ohm loudspeakers (8 ohms is the "rated" or "nominal" impedance), for example, have minimum impedances of 6-ohms, or even as low as 5-ohms. Two of these loudspeakers in parallel would have a minimum impedance of 2.5-ohms, which would still be within the safe limits for your PX-2200 Mixer.

The easiest way to describe the change in power output with different load impedances is to take an example. Let's use the Fender SPL-9000 Power Amplifier, which is rated at 450 watts per channel into a 4-ohm load. (The SPL-9000 has a minimum load impedance of 2 ohms, even though its 450 watt power rating is at 4 ohms). 450 watts into 4-ohms means exactly that. If you connect a 4 ohm loudspeaker to one channel of the SPL-9000, the amplifier will produce as much as 450 watts into that loudspeaker. If you connect two, 8-ohm loudspeakers (in parallel) to one channel of the SPL-9000, the SPL-9000 will again, produce as much as 450 watts into the

resulting total impedance of 4 ohms. Each 8-ohm loudspeaker in this example will receive exactly one half of the total power, or, a maximum of 225 watts.

If you now connect a single 8-ohm loudspeaker to one channel of the SPL-9000, that loudspeaker will still only receive a maximum of about 225 watts (The actual power will be slightly higher). If you connect a single 16-ohm loudspeaker, it will receive a maximum of about 112.5 watts. In other words, doubling the load impedance halves the power output of a power amplifier. Conversely, halving the load impedance doubles the amplifier's power output. Remembering this simple relationship can help you make sure that a loudspeaker and power amplifier will be compatible in terms of impedance and power levels, thus helping protect your loudspeakers and your power amplifiers.

Understanding Balanced and Unbalanced Lines.

The term "line" refers here to a cable or connection between two pieces of audio equipment. Every audio signal requires at least two wires. In an "unbalanced" line (no, we are not referring to your mental state, so don't take offense), the shield (outer conductor) is also one of the audio signal wires. Thus, an unbalanced line needs only the shield and one additional wire (a total of two wires). The term "shield" is used to describe that wires intended function, i.e., to "shield" the other wire (and hence the signal) from stray pickup of unwanted signals (truckers on CB, noise, and other garbage). Often, the shield wire will be a braid, or wrapped totally around the other wire. The inside wire is "hot", or the "send", and the shield is "the return", or "cold".

Balanced, Floating and Unbalanced Lines

A Balanced Line Connecting Two Audio Devices

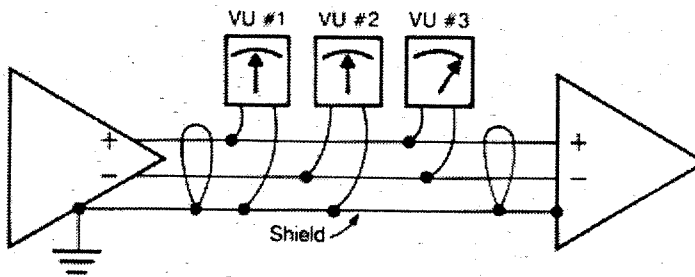

On a true "balanced" line, VU #1 and VU #2 will read exactly $\frac{1}{2}$ the value of VU #3. On a "floating" line, the readings of VU #1 and VU #2 are undetermined. Both balanced and floating lines help reject noise pickup.

An Unbalanced Line Connecting Two Audio Devices

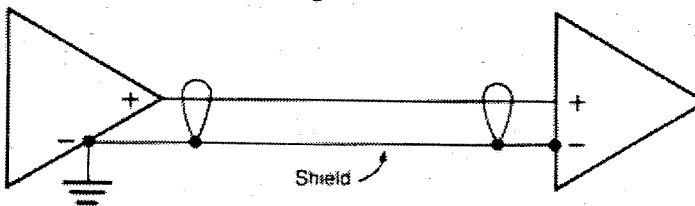

In a balanced line, the shield does not carry audio signal. Thus, a balanced line requires two additional wires to carry the audio signal (for a total of three wires). In a true balanced line, the audio signal level is "balanced" between the two audio wires, and the shield, which is normally grounded. Thus, two VU meters, each connected between one of the audio wires and the shield, would display the same reading ($\frac{1}{2}$ the total audio signal level).

The primary advantage of a balanced line is that it is much less likely to pick up external electronic noises (hum, buzzing, static, radio stations) than an unbalanced line.

This reduced noise pickup is very important for low-level devices like microphones. Thus, the Lo-Z inputs on your Fender PX-2200 are all balanced, and allow you to use either balanced or unbalanced microphones.

Like the microphone inputs, the Line inputs on your Fender PX-2200 are all balanced as well, allowing you to use balanced or unbalanced line-level devices. Some so-called "balanced" devices are actually "floating". On a "floating" line, connecting two VU meters between each of the two wires and ground, would show undetermined results, that is, each wire "floats" at an undetermined voltage from ground. In most cases, floating lines provide the same advantages as balanced lines, but not in all cases.

In other words, the difference for our purposes is academic and the two terms may be treated as equivalent.

Connectors and Cabling.

As simple a subject as this may seem, faulty connectors and cabling are the source of a majority of sound system problems.

Well-made cabling, of the proper type, with the right connectors for the job, on the other hand, will keep your system operating at maximum efficiency with a minimum of noise pickup. Here are some tips on how to do it right.

Some General Notes on Cable.

No, we are not talking about MTV and ESPN here, so put down those remote controls and pay attention. A cable is a group of two or more wires, usually in a single outer (insulating) sheath, and designed for a particular function. Cables for portable audio systems should always be made from stranded, not solid, wire. Solid wire cables will break after the repeated flexing of portable usage. Shields should be braided or spiral wrapped wire, not foil, for the same reason.

Some General Notes on Connectors.

There are only a few types of connectors in general use in professional audio. The most common of these are:

1) "XLR" Type Connectors. The term "XLR" was first used by the Cannon Company, but has almost become a generic label for these high-quality audio connectors, now made not only by Cannon, but also by Switchcraft, Neutrik, ADC and others. XLRs are the connector of choice for any balanced low-level (microphone) or line-level audio signal.

2) 1/4" Phone Plugs.

The term "phone" comes from the telephone company, who used a type of phone plug in their early, non-automated, switchboards. Recording studio patch bays are close relatives of these telephone switchboards, and, again, use some type of phone plug.

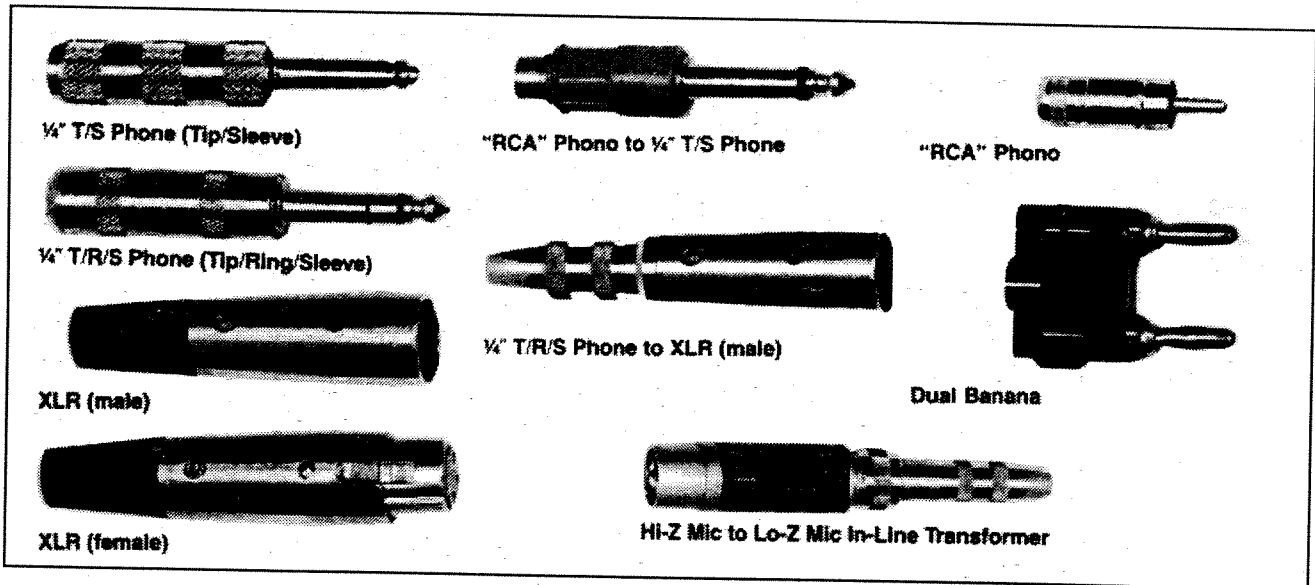

The most common type of phone plug used in pro audio has a 1/4" diameter shank and comes in a two-wire (known as "Tip/Sleeve" or "TS") version, and three-wire (known as "Tip/Ring/Sleeve" or "TRS") versions.

1/4" phone plugs are commonly used for instrument amplifiers (hence the term "guitar" cords), Hi-Z microphones, and other signals. TRS jacks are used extensively on your PX-2200 Mixer.

Beware when you purchase a "blister pack" phone plug, however, because smaller diameter varieties exist (which are in metric due to the fact they are made in the Orient. They may not work properly in some pieces of audio equipment, causing intermittent problems). Smaller varieties of phone plugs, (typically 1/8" in diameter) like those used on portable hi-fi equipment, are seldom used in pro audio. Unlike XLRs, which are almost invariably high quality, the quality of commercially available phone plugs can vary widely. Your best bet is to purchase a well known brand name (like Switchcraft or Neutrik) at a reputable audio store (like your Fender dealer).

3) "RCA" Type Phono Plugs.

Note the term "phono", not "phone", indicating that these plugs got their start on phonographs (assumably those manufactured by the RCA company). Phono plugs, or "RCAs", are used primarily on hi-fi and "semi-pro" audio equipment. Most likely, you will need to use them to, say, hookup a CD player, DAT recorder, or even a multi-track audio recorder to your Fender Mixer. Phono plugs, however, are fragile and do not make good general purpose pro audio connectors. We have included two sets of RCA jacks on your Fender PX-2200. The first is a left and right "Record" output, used to plug into the record "inputs" of a DAT or cassette deck. The second, is a set of "Playback" inputs, for easily hooking the outputs of a DAT, Cassette, or CD player into your PX-2200.

Cable and Connectors For Microphones and Other Low-Level Devices.

Lo-Z balanced microphones (most professional microphones are in this category) use shielded, two wire cable and XLR type connectors.

Hi-Z (unbalanced) microphones usually use a 1/4" phone plug connector. Microphone cable should have a flexible, tough outer sheath, a braided or spiral wrapped shield, and stranded inner wires.

Although the XLR type connector is an industry standard for Lo-Z balanced microphones, unfortunately, the wiring of these connectors *IS NOT* completely standardized. While pin 1 on the connector is almost always connected to the cable shield, some manufacturers use pin 2 as "high", "hot", or "+", and other manufacturers use pin 3 as "high", "hot", or "+" (with the remaining pin "low", "cold", or "-").

This means that if you use two microphones from different manufacturers, with different "+" pins, the two microphones will be "out of phase" with each other, and that can cause undesirable effects like "comb filtering", when the microphones are very near each other, and both are picking up the same sound source (see "What Do We Mean By Phasing and Polarity").

About your only defense against this problem is to make sure you know which is the "+" pin on any microphone you use (and on any piece of electronic equipment you use that has XLR connectors for inputs or outputs), and try not to use both types in the same system. Your Fender dealer will also be able to help you resolve this problem with a special type of adapter or cable, known as a "polarity reversal" or "phase reversal" adapter.

The Electrical Representation Of Sound.

In order to better understand some of the principles involved, and to have a basis for what will come later, let's have a brief lesson in basic electricity, and how wires conduct that electricity. We promise, we won't dwell on this so long that you turn into a propeller head, but a little basic knowledge never hurt!

When sound waves impact a microphone (or other electronic input device) they are converted from waves of air pressure to waves of electricity, and are subject to the laws of electricity (thank you Thomas Edison). It is the existence of these electrical principles, and our manipulation of them, that is the foundation of the modern sound system and all its benefits. It is imperative that one understand some of the basics of electricity if one is going to understand audio production today.

Signal Voltage/Amplitude.

A wave by any other name is still a wave (unless of course it's a particle). An audio signal is an electrical representation of a sound, in the form of a fluctuating current. When a sound wave meets a microphone it changes its basic make up—from acoustic to electrical energy—but it also remains the same (a wave).

Eventually, it will be changed back—from electrical to acoustic energy. In the process, we may have increased its gain (the amplitude of the wave), or otherwise altered the form of the wave, but it still remains, essentially, the same thing.

Within the limits of the audio equipment, the signal voltage, or current, fluctuates at exactly the same rate as the acoustical energy that it represents, and the amplitude of the audio signal—the signal level—is proportionate to the amplitude of the original sound wave.

Properties of Electricity.

There are four basic properties of electricity that are necessary to an understanding of sound reproduction. These are **voltage, current, resistance, and power.**

If we take a trip to the railroad station, we may get a better glimpse at how these four elements interact.

As the Atchison-Topeka pulls into the station it pulls up on the Santa Fe, just sitting there—unbuckled—waiting to get it together. Let's face it, the collision is not pretty, but it gives us a beautiful demonstration of electrical current as the engine car of the A-T rams the caboose of the Santa Fe, sending it hurtling into the baggage car, which in turn rams the mail car, which in turn rams the dining car where a formerly delighted group of celebrants have just had their hors d'oeuvres dumped unceremoniously on their laps (this thing is getting uglier by the minute), the dining car hurtles into the club car... to the passenger car... to the engine, which having nothing to ram into hurtles off the track, and through the wall of the passenger terminal!

Now, while the cars have not moved a great distance (with the exception of the poor solitary Santa Fe engine), they have communicated a great deal of energy. The force (**voltage**) of the Atchison-Topeka has sent the cars of the Santa Fe (**current**) hurtling into each other and eventually created an enormous amount of havoc (**power**) at the other end. Things would have been much worse if the brakes on the cars (**resistance**) had not been locked, keeping them at least partially weighted against a free rolling disaster.

Voltage = PRESSURE!

Voltage can be thought of as electrical pressure. It is the force which causes current to flow through an electronic circuit. The measurement of voltage is...ta dah... **Volts.**

Current.

Everything around us is made up of atoms, and atoms are made up of protons, neutrons, and electrons. In some materials, the electrons (which move around outside the nucleus of the atom) can be made to jump from one atom to another, creating what we call **current**. Materials with loosely bound electrons (such as most metals) are referred to as **conductors**, because they allow this current to flow easily. The electrons in other materials (like rubber, or ceramic) are more tightly bound together and don't flow so easily (maybe they just like each other more).

Such materials are called **insulators**, and as you may have guessed, prove very useful in situations where you don't want current to go. Current is rated in **Amperes** (or **Amps**), and comes in two different flavors, named for the manner in which the electrons are made to flow.

Direct Current.

Direct current, or **DC**, is a single-minded optimist kind of phenomenon. The electrons flow in one resolute direction—from negative to positive. DC moves on a forward juggernaut, never looking back, never reconsidering, and never stopping to smell the flowers. Batteries operate with Direct Current. The simplicity of the set up allows for their compact nature.

Alternating Current.

Conversely, alternating current or **AC**, is truly a schizophrenic member of the electrical community. It switches back and forth from positive to negative several times a second. House current, for example, is 60 cycles AC. That means that the current at the two prongs of a home outlet changes from positive to negative 60 times every second. (I know some people that do that, but come on!) The neat thing about AC is that it has a particular affinity for one of our old friends, the audio signal, or sine wave. As the current flows in one direction, it creates a voltage peak, which alternates with a voltage drop of the same size. Convenient for those of us in audio, this back & forth/up & down behavior precisely resembles the up and down nature of the alternating compression and rarefaction in a sound wave.

What Do We Mean By Phasing and Polarity?

OK, so how does this all get back to cables and audio hookup? Well, let's think for a minute about polarity. Every electrical signal or point of connection has a "polarity". Electrons (remember those tiny parts of an atom?) make up any electrical signal, and they have an unstoppable desire to flow from negative to positively charged points. As we discussed above, this is DC.

A transistor radio battery has a "+" and a "-" terminal.

Put it in a radio with its "+" terminal connected to the radio's "+" terminal and the battery's polarity is said to be normal. Turn the battery around so that its "+" terminal is connected to the radio's "-" terminal, and you will have a very unhappy, smoking radio (although all 9 volt batteries are "keyed" to prevent you from hooking them up backwards). But I digress, if the battery was hooked up backwards, it could be said that the battery's polarity is reversed.

The polarity of a microphone is a bit more complex, but similar in concept. Audio, as you may have guessed by now, is an AC signal. A sound wave in the air consists of alternate layers of compressed and rarefied (uncompressed) air.

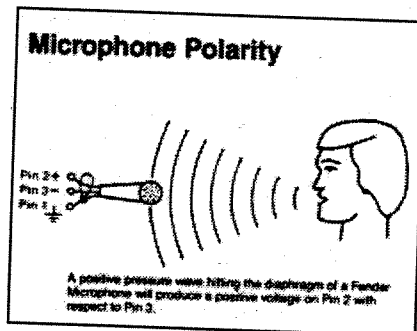

The compressed layers are defined as "positive pressure"; the rarefied layers are defined as "negative pressure".

When a positive pressure wave hits the diaphragm of the microphone, it produces a positive voltage on one of the pins of the microphone connector (relative to one of the other pins). That pin is the "+" pin of the microphone connector (the other pin is the "-" pin). Thus, if pin 2 of the microphone connector is specified as the "+" connector, you know that a positive pressure wave striking the diaphragm of the microphone will produce a positive voltage on pin 2 of the connector, with pin 3 used as the reference

or "-" pin, and pin 1 the shield or ground). If you plug this microphone into a mixer which also uses pin 2 as its "+" pin, the polarity will be "normal". If the mixer uses pin 3 as its "+" pin, the polarity will be "reversed".

Reversed polarity between a microphone and a mixer is seldom a problem. Using two microphones with different polarity standards can, on the other hand, be a real problem, at least when the microphones are close together and both picking up the same sound source.

The reason is that the same positive pressure wave, striking the diaphragms of both microphones, will cause a positive voltage on pin 2 of one microphone and a negative voltage on pin 2 of the other microphone!

When these two microphones are mixed together inside a mixer, the positive voltage from one microphone partially or completely cancels the negative voltage from the other microphone and you end up with bad sound or no sound at all!

An Exercise: Help Me, I'm Phasing.....

You can experience this effect by taking two microphones of the same model and brand, and using a polarity reversal adapter with one of them (see "Adapters").

Plug each microphone into an Input Channel on your PX-2200 Mixer and set the controls on both Input Channels the same. Start, however, with one fader all the way down and adjust the other fader for a comfortable listening level. Now, holding the two microphones very close together, talk into both of them and bring up the second fader (which has the microphone plugged into the polarity reversal adapter, and then into the mixer).

As the level of the second fader approaches the level of the first fader, the sound level goes down, not up!

You can check the polarity of unknown microphones in a similar manner. Select a standard microphone (one whose polarity is known) and check all the others against this standard, just like you did in the above exercise (omit the polarity reversal adapter). If the unknown microphone is out-of-polarity with the standard microphone, the level will go down as you bring up the second fader.

You can use a polarity reversal adapter with an out-of-polarity microphone to bring it back to standard polarity.

Or, it's okay to use an out-of-polarity microphone without the polarity reversal adapter. Just don't use two microphones with opposite polarity to mic the same (or a nearby) instrument or voice.

Phase and polarity are related, but different, concepts even though the terms are often used inter-changeably. When you hear the term "out-of-phase", for example, that probably means

reversed polarity (reversed polarity is a more technically accurate description of the problem discussed in the previous paragraph).

Phase is a way of measuring, in degrees, the distance between two points in a sound wave, or of two points in the corresponding electrical signal. In the first part of the diagram, you can see that the phase difference between one positive portion of this sound wave and the next positive portion of the sound wave is always 360 degrees. The wave-form shown is called a sine wave, and is typical only of very pure tone instruments like a flute.

Most sound waves are much more complex. Yet, for a discussion of phase, this wave form is useful because of its simplicity. If the distance between one positive portion of the wave and the next positive portion of the wave is always 360 degrees, then the distance between a positive portion and the adjacent negative portion of the wave must be 180 degrees. If you reverse the polarity of a microphone, that causes the positive electrical signal from the microphone to become negative, and vice-versa.

Thus, a polarity reversal is very similar to a 180 degree phase shift (moving from the positive portion of the wave to the negative portion of the wave).

This is the origin of the use of "out-of-phase" or, 180 degrees out-of-phase, to mean polarity reversal.

A true phase shift, however, can be anywhere from 0 degrees to 360 degrees (or even a large multiple of 360 degrees). In the second part of the diagram you see a flute player and the sound coming from the flute.

Two microphones are placed at different distances from the flute.

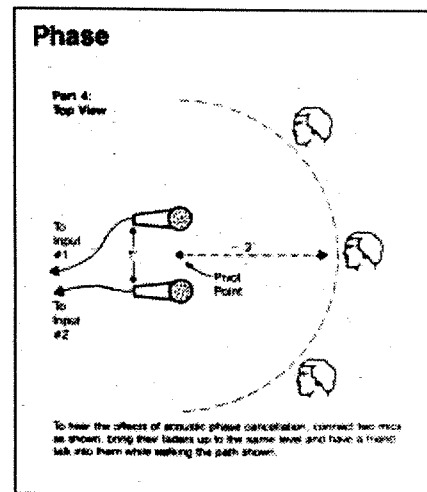

Because these two microphones are at different points in the sound wave, we can say that they are truly "out-of-phase" with each other, even though their polarity is the same.

This kind of out-of-phase condition causes the problem known as comb filtering. Comb filtering causes a flat frequency response to look like the third part of the diagram.

Polarity & Phasing: An Exercise.

If you want to hear this kind of problem, take your two microphones again and connect them to two Input Channels of your PX-2200 Mixer, but this time don't use the polarity reversal adapter. Place the microphones a foot or so apart on two stands, bring the faders on both Input Channels up to the same point, and have a friend talk into both microphones at the same time from a position like that shown in the fourth part of the diagram. Now, have your friend keep talking, but walk around the pivot point shown while facing the microphones. The sound quality will change dramatically as your friend moves around the microphones.

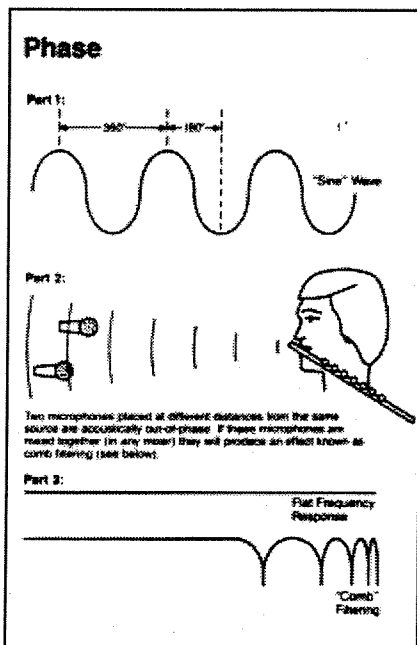

This effect is usually called "phasing" (accurately!) and the special effects devices called "phasers" duplicate this effect electronically, by slightly delaying the signal in time. In sound systems, however, for normal operation, the phasing effect is undesirable and the best way to prevent it is to use a single microphone for each source (for each singer or group of singers and for each instrument), with minimum leakage of the sound source into other microphones. For individual singers or instruments, ask the performer to stay as close as possible to the microphone. This allows you to turn down the fader on that microphone which minimizes the pickup from other sources (and therefore minimizes phasing problems from those other sources).

This same problem happens between two loudspeakers, and you can experience it by playing a constant source at equal level through two loudspeakers, separated by a few feet. Use the inter-station noise from an F.M. tuner (or a "pink noise" source if available), or use a single microphone (in another room) picking up a sustained guitar or piano chord.

Walk between the two speakers (at some distance from them) and listen to the results. The radio inter-station or pink noise source will sound like a jet plane taking off (with similar effects on the guitar or piano).

It's almost impossible to completely eliminate this problem in a real sound system, but you can minimize it by using each loudspeaker to cover a specific area of the room. In other words, don't overlap the coverage any more than you have to. It's those overlap areas where the phasing problems occur.

Fortunately, unless you have critical listeners in your audience, and you are reinforcing sustained chords, and the listeners are moving from point to point, the audible effects of phasing are not great. Still, for the best sound quality, everywhere in a room, it's a good idea to try to minimize these effects before a performance begins.

Microphone "Snake" Cables.

A "snake" cable is actually a group of microphone or line-level cables all in one outer sheath. These cables use foil shields to reduce their overall diameter to a reasonable size. Because of the fragility of the foil shields in a snake cable (and because of the high cost per foot) you must take extra care in their handling. Avoid sharp bends in these cables. Also avoid placing heavy objects on a snake cable, or rolling heavy objects across them. Snake cables can be a money saver and a time saver when you are setting up a large, multi-microphone system. They also allow you to move your mixer off the stage, to a place in the audience where you can hear better! Ask your Fender dealer for help in selecting a snake for your system.

Cable and Connectors For Line-Level Devices.

Line-level devices normally use the same type of cable and connectors as microphones, instruments, and other low-level devices.

That is, balanced line-level devices normally use XLR type connectors and unbalanced line-level devices normally use 1/4" phone plug connectors. Some balanced line level devices use three-conductor, 1/4" Tip/Ring/Sleeve (TRS) connectors. Polarity is, again, unfortunately not standardized on balanced line level devices using XLR connectors.

Either pin 2 or pin 3 may be the "+" pin (pin 1 will almost always be the shield or ground). Thus, you should check the polarity of any unfamiliar device you may be using.

Cable and Connectors For Loudspeakers.

Speaker cable carries much higher levels of electrical power than either microphone or line-level cable. For this reason, speaker cables use larger gauge wire. Typical speaker cable uses anywhere from #18 gauge wire to as large as #10 wire. #18 gauge wire is suitable only for low-power loudspeakers (like the hi-fi speakers in your home). #16 gauge wire is suitable for short runs (less than 25 feet) of low to medium power pro audio loudspeakers. #14 gauge wire is suitable for most pro audio work unless loudspeaker runs are longer than about 75 feet. In that case, #12 gauge wire should be used. For very long runs of high power speaker cable, use #10 gauge (or even #8 gauge) wire. A better way to handle long speaker runs, however, is to move the power amplifier closer to the loudspeakers and run line-level signals (in shielded cable) over the long distance.

Loudspeaker connectors are another story. The most common loudspeaker connector in pro audio is the 1/4" phone plug. Unless you use very high quality phone plugs, however, they are actually not very suitable for the high current use they get in pro audio. Thus 1/4" phone plugs are only suitable for low and medium level loudspeakers (perhaps up to 300 watts or so per loudspeaker). For higher power loudspeakers, a higher current connector like a "dual banana" connector is a good choice. XLR connectors are

Adapter Wiring Diagrams

T/S Phone Plug to XLR Connector (for Pin 2 "high" systems)

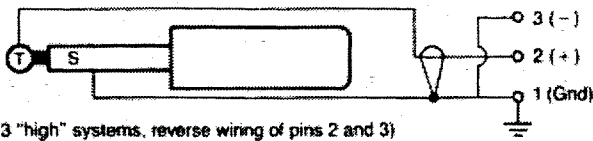

T/R/S Phone Plug to XLR Connector (for Pin 2 "high" systems)

Use this wiring to connect a balanced, line-level device to the Hi-Z In jack.

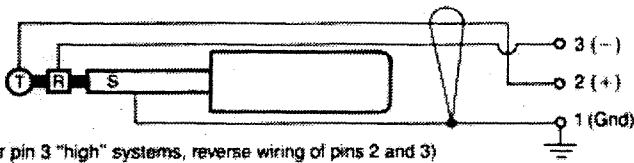

Wiring for 3000 Mixer Insertion Connector

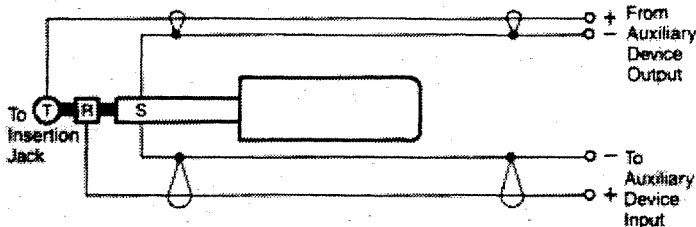

XLR Polarity Reversal Adapter Use Switchcraft Part # S3FM

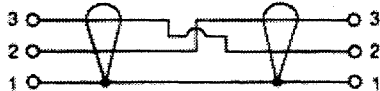

sometimes used for loudspeaker connectors, but their current capacity is limited too, and they should not be used for higher power capacity systems. Perhaps the best loudspeaker connector (outside of the dual banana plug) is the new Neutrik "Speakon" connectors.

These are 4 conductor and 8 conductor connectors, and are most often used for hooking up bi-amplified or tri-amplified sound systems, using a single connector. Some loudspeaker systems you may encounter, however, may have this style of connector.

Check the speaker systems owners manual to see how to wire that particular speaker to your PX-2200.

Adapters.

If all audio devices used the same connector, we wouldn't need adapters. Suffice it to say that we do need them, often! Take care in using the adapters shown here. They will, in most cases, allow you to connect one type of device to another.

They do not help you maintain impedance and level compatibility! In some cases, you may need a pad, or a transformer (or even a preamplifier) along with an adapter in order to be able to connect two audio devices together. Consult your Fender dealer if you need help with these connections.

Pads and Transformers.

Attenuator Pads.

An attenuator "pad" is a resistor circuit that reduces the output level from a source device to make it "level compatible" with a load device. For example, a pad could be used to connect the output of a +4 dB limiter to the -10 dB GEQ In jack on your PX-2200 Mixer.

The pads shown here are of two types: balanced and unbalanced. The balanced pads are meant for balanced microphones or for low-source impedance balanced line-level devices. In most cases, however, you will not need a microphone pad with your PX-2200 Mixer, since proper adjustment of the Trim control achieves the necessary level compatibility. The unbalanced pads are meant for low source-impedance, line-level devices and should not be used with high-impedance microphones.

The balanced pads may be constructed inside a Switchcraft Model S3FM using 1/4-watt or 1/2-watt resistors. The unbalanced pads may be constructed in a small metal parts box or, using 1/4-watt resistors and a lot of care, they may be assembled inside a 1/4" phone plug (make sure to mark the cable that has such a pad/plug attached).

Hi-Z Mic to Lo-Z Mic In-Line Transformers.

Transformers are devices that can sometimes be used to connect devices with unlike impedances and levels. For example, a "Hi-Z" to "Lo-Z" microphone transformer converts the high (voltage) level and high impedance of a high impedance microphone, to the low (voltage) level and low impedance of a low impedance microphone.

Other transformers can convert high impedance, high line-level devices to low impedance, low line-level devices.

Because a transformer is not an active device, however, it cannot amplify. In fact, most audio transformers have some loss. Thus, when you convert from high impedance to low impedance, for example, you also convert from high-level to low-level. A transformer cannot convert impedance without also converting level (usually in the direction we don't want). Transformers are also level sensitive. That is, a microphone "Hi-Z" to "Lo-Z" transformer cannot be used for line-level impedance conversion (it would distort). Neither can a line-level transformer be used for microphone-level conversions (it would also distort, although in a different manner). Thus, when selecting transformers, you must define your needs in terms of both the impedance ratio desired, and the level of the devices that will be connected to the transformer. One valuable use of a microphone "Hi-Z" to "Lo-Z" transformer is to convert a high impedance microphone to low impedance, to allow it to be used with longer cable lengths and balanced microphone lines. A high impedance to low impedance line-level transformer could be used to allow a high impedance, line-level device to be used with longer cable lengths, too.

Pads

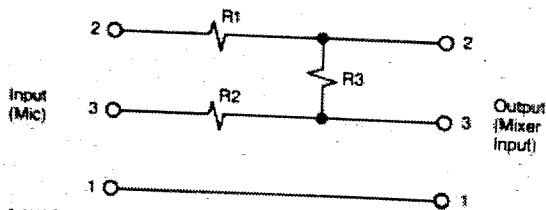

A "U" Pad for use with Lo-Z microphones (or low-impedance, balanced, line-level devices). Construct with 1/2-watt resistors in Switchcraft Part #S3FM.

dB Attenuation	R1	R2	R3
10 dB	1500Ω	1500Ω	1500Ω
16 dB	1500Ω	1500Ω	560Ω
20 dB	1500Ω	1500Ω	330Ω

(Values assume 3000 Mixer input impedance of 8kΩ. However, pads will work well with most Lo-Z mics and mixers.)

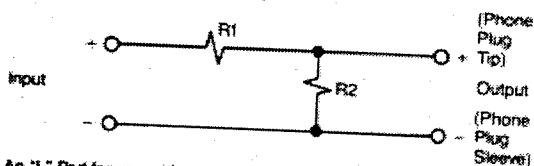

An "L" Pad for use with unbalanced, line-level outputs. Use 16 dB pad between Pre Amp Out and Power Amp In jacks to allow "D" VU Position to be "nominal" (see "The VU Meters"). Construct in a metal "project box". Use 1/4-watt or 1/2-watt resistors.

dB Attenuation	R1	R2
10 dB	10kΩ	5600Ω
16 dB	10kΩ	2200Ω
20 dB	10kΩ	1000Ω

(Values assume 3000 Mixer Power Amp In input impedance of 16kΩ.)

For more specific information on pads and transformers, consult your Fender dealer, or one of the recommended reference books listed in the bibliography of this owners manual.

Grounding and Shielding.

Caution!

In any audio system installation, governmental and insurance underwriters' electrical codes must be observed. These codes are based on safety, and may vary in different localities.

Fender Musical Instruments Corp. shall not be liable for incidental or consequential damages, including injury to persons or property, resulting from improper, unsafe, or illegal installation of a Fender PX-2200 Series Mixer, or of any related equipment; neither shall Fender Musical Instruments Corp. be liable for any such damages arising from defects or damage resulting from accident, neglect, misuse, modification, mistreatment, tampering, or any act of nature.

Using a Pad

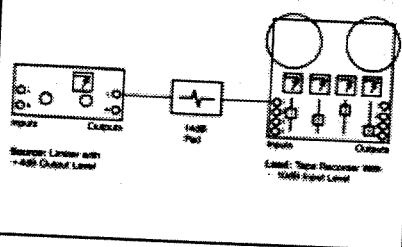

Only qualified personnel should attempt to use the PX-2200. Any person installing and/or operating the PX-2200 assumes full responsibility for the safe use of the PX-2200, and all other devices connected to it.

Under no circumstances, should the A.C. ground pin (round prong on the A.C. power cord) be disabled or lifted. It must always be used with a properly grounded A.C. receptacle.

Grounding for Safety.

The third (round) prong on the A.C. cable of your PX-2200 Mixer is the A.C. safety ground. It is connected to the metal chassis of your PX-2200 Mixers power amplifier panel. When you plug this cable into a properly wired A.C. receptacle, the chassis of your Mixer is connected to the A.C. ground through the third prong of the A.C. receptacle.

Grounding to Reduce External Noise Pickup .

The primary reason we ground our audio equipment is for *safety*. An important secondary reason is that, with AC powered equipment, under some conditions; proper grounding can help reduce external noise pickup. The third reason that we must pay attention to grounding is that, while proper grounding won't always reduce external noise pickup, poor grounding can unquestionably increase external noise pickup!

Poor grounding practice usually results in "ground loops" and avoiding these ground loops is the second most important part of proper grounding (the first most important part, of course, is maintaining the safety ground). It's worth noting that, by using balanced connections between two pieces of audio equipment, you can "lift" (disconnect) the shield at the "sending" end of the

audio cable to interrupt the type of ground loop (discussed in Example 2). Since, in a balanced line, the shield does not carry audio signal, you can disconnect the shield at one end without interrupting the audio signal (and without disrupting the effectiveness of the shield). This may require the use of outboard transformers or adapters.

Using Proper Shielding to Reduce Noise Pickup.

Proper grounding helps prevent the pickup of noise that is transmitted magnetically. Magnetically transmitted noise most often comes from motors, refrigerators, air conditioners, or, more commonly in audio, from large A.C. power transformers (either building transformers or the power transformers in a power amplifier or other piece of audio equipment).

Proper shielding, on the other hand, helps prevent pickup of noise that is transmitted capacitively. Capacitively transmitted noise may be in the form of radio waves from a radio station or CB radio, or it may be in the form of "static" from certain types of motors or from lighting dimmers

(Noise from lighting dimmers may also come through the A.C. lines, as discussed below). Fortunately, proper shielding is pretty easy. Just make sure that you are using high-quality shielded cables on all microphones, and on all line-level equipment. Some very low cost audio cables (including some guitar cables) have poor quality shields. Watch for these potential sources of noise pickup.

It is seldom necessary (and in fact, can be extremely problematic) to use shielded cable for your loudspeakers, since they operate at very high levels.

The noise picked up by a loudspeaker cable is actually as high of a level as the noise picked up by a microphone cable, but, because the loudspeaker operates at a much higher level than the microphone, the signal to noise ratio is vastly better, and the noise is seldom a problem.

Reducing Noise Pickup From A.C. Lines.

Some types of noise, notably noise from lighting dimmers, gets into your audio equipment from the A.C. power cable. There are two ways to reduce this problem:

- 1) Install filters on the dimmer circuits (filters on your audio equipment won't help as much and probably will cost a lot more), and,
- 2) Make sure the dimmer circuits are properly loaded. That is, if the dimmers are rated for 1500-watt loads, make sure they have 1500 watts worth of lighting connected to them (Or add a suitable "dummy load" to simulate a full rated load on the dimmer). The reason for this is that the noise filters (if there are any), will only work properly when the dimmer is loaded properly (this is an example of impedance "matching").
- 3) Make sure the lighting circuits are properly grounded (improper grounding can increase noise levels at the source as well as at your audio equipment).
- 4) Use a different A.C. circuit (you know it's a different circuit if it uses a different house fuse or circuit breaker).

Finding The Source Of A Noise Problem.

This can be the hardest part. A "buzzing" noise in your system may be attributable to a set of lighting dimmers in the house, but you must find out how the noise gets transmitted from those dimmers into your system before you can cure the problem. Is the noise transmitted magnetically? If so, eliminating ground loops in your system should help. Is it transmitted capacitively? If so, look for poor quality shields or faulty connectors. Is it transmitted through the A.C. power lines? Install filters at the source of the problem, or move your audio equipment to a different A.C. circuit. In the end, you may have to try all of these methods to solve a given problem, but if your system is carefully grounded and properly shielded in the first place, you'll be less likely to experience a noise pickup problem. Here then are some final tips on noise reduction.

More Tips On Reducing Noise Pickup.

1) Rack mount your equipment. Rack mounting, especially when the rack mount rails are made of metal, connects together the chassis of all your equipment into a unitized shield. Perhaps more important, rack mounting allows you to use shorter connecting cables and to keep them closer together. When rack mounting large power amplifiers, however, do not place sensitive, low-level equipment right next to them in the rack. The power transformer in a large power amplifier can produce a large alternating magnetic field that can "induce" hum in low-level equipment. Rack mounting can however, sometimes cause a ground loop, by tying the chassis together through the rack rails.

If you add a new piece of rack mount gear to your system, and get a ground loop, try removing the piece by disconnecting all audio cables, and unplugging the new piece from the A.C. strip. If the hum goes away, you have found the offender. There are commercially available insulators available (Hum-Frees, etc.) which electrically isolate the unit from the rack rails, while still allowing it to be rack mounted. You may also be able to lift the shield or the pin 1 ground on a balanced line, on either the input or output of the unit, and accomplish the same result.

2) Keep your cables short. Rack mounting can help here too. So can simple neatness.

3) Keep cables of the same type close together. By "the same type", we mean cables that carry the same signal level (like line-level signals).

4) Keep cables of different types as far apart as possible. That means keep your microphone cables away from loudspeaker cables, and keep all audio cables away from the A.C. power cables. On long cable runs, keep line-level cables and microphone cables separated. If you absolutely must cross two different cable types (such as A.C. and microphone cables), orient them at 90 degree right angles from each other at the place they cross.

5) It's a common, but risky, procedure to run microphones through a "snake" (a multi-microphone cable) to a mixer and, then run the outputs from the mixer back to the power amplifier through the same snake.

This mixing of levels, in a long cable run (greater than about 25 feet) could be a problem, and can cause a form of electronic feedback that could cause harmful oscillations in your mixer or other pieces of your equipment.

6) Keep your wiring "neat". Carefully made cables, of the proper length (not too long) and carefully laid out on a stage or in an installation, are probably the best way of all to reduce external noise pickup.

Dealing With Feedback, Hum, Hiss and Other Noises.

Feedback.

Feedback is the "howling" sound caused by bringing a microphone too close to a loudspeaker. As simple as it seems, however, feedback is actually a complex phenomenon and solving feedback problems involves working with a number of variables.

Equalizers are commonly used to control feedback. They aren't necessarily the best way, as discussed below. When you use an equalizer, like the Graphic Equalizers on your PX-2200 Mixer, to help control feedback, you pay a price. That price is an uneven frequency response (and the resulting UN-natural sound quality) caused by using the Graphic Equalizer to control feedback (rather than "equalize" the system to make it sound good). This price may be acceptable on a monitor system however, since the performers, not the audience, are the only ones who hear it.

You can pre-set the Monitor Graphic Equalizers for minimum feedback by starting out with all the Graphic Equalizer controls at their mid position and then carefully turning up the Monitor (1 or 2) fader until you get just the beginning "ringing" of feedback. We urge care in this operation, because high level, sustained feedback can damage loudspeakers (and ears!). Then, using your musician's ears, or a real-time analyzer determine the approximate frequency of the feedback, and pull down the Graphic Equalizer control nearest the feedback frequency. Pull it down just enough to quiet the feedback and then increase the Monitor fader a little more. Chances are, after you do this two or three times, a different feedback frequency will appear.

Work on two or three of these feedback frequencies at the most. Trying to cure more than that will result in a very unnatural sound quality (because of the settings of the Graphic Equalizer) and also will result in diminishing returns. If you find yourself turning down nearly all of the bands, think for a moment about what you are doing. By pulling down a specific band, you are reducing the level of that particular frequency. By pulling down a large number of sliders to reduce feedback, in essence, what you are trying to do is to reduce the overall level! A better solution is to center the equalizers and just back off the monitor master fader slightly, and then find another solution to the problem of feedback.

A "narrow-band" third octave equalizer (with 30 bands typically) or a "sweepable notch filter" may work better at feedback reduction than the relatively wide-band filters in your PX-2200 Mixer's Graphic Equalizers (which, unlike narrow-band types, were designed primarily to enhance the audio sound quality). You will, however, always reach a point of diminishing returns in this process, and remember that almost any change in the stage setup can change the entire feedback situation in your system!

Acoustic Solutions To Feedback.

Feedback is an acoustic problem. Thus, the primary way to deal with feedback is to trace its source and attempt to stop it by acoustic means (this may be as simple as altering your stage setup). First, find out which loudspeaker and which microphone are causing the feedback. You can do this by simply turning off all but one microphone, and all but one loudspeaker, and then trying the next microphone, and so on.

When you find out which microphone and loudspeaker are the culprits, try moving one or the other (or several if it seems like several mics are involved). Sometimes a small microphone or speaker movement can cure feedback, since feedback can be caused by reflections from floors, walls, or even table-tops, as well as direct sound from a loudspeaker to a microphone. You may also try a different microphone. As discussed in the section entitled "Choosing and Using Microphones", a cardioid microphone may help lower your system's feedback potential.

Teaching the performers to work the mic close to their mouths or instruments can help immeasurably in controlling feedback, because this technique allows you to reduce fader levels (this also reduces bleed (or leakage) from one instrument to more than one microphone). Only after you have tried all of these cures should you resort to using an equalizer to control feedback.

Hums & Buzzes.

Hum and buzzing may be caused by internal problems in a piece of audio equipment, or they may be caused by external noise sources. If the problem is internal to a piece of audio equipment, the solution is simple: get it fixed. If the problem is pickup of external noise, the solution may not be so simple. Read the sections entitled "Impedance and Level Watching," "Grounding and Shielding" and "Cable and Connectors" for some suggestions.

Hiss .

Hiss is random electronic noise that is generated by every piece of audio equipment. A certain amount of electronic noise is in-escapable in any piece of audio gear. In a high quality audio device like your PX-2200 Mixer, this hiss level is extremely low. Some hiss may be generated, however, when we connect two pieces of audio equipment together (see "Impedance and Level Matching"). You actually have a great deal of control over this process. Simply adjusting the Trim control properly for each Input Channel will help a lot. That's because, properly adjusted, the Trim control boosts the level of an incoming signal as high as possible, without causing clipping of the Input Channel. This higher level signal helps bury the hiss noise (bringing meaning to the term "signal-to-noise ratio").

Another way you can reduce hiss noise is to simply plug devices into the appropriate input. For example, if you plugged a Hi-Z microphone into the line input jack and turned up the trim control far enough, you could probably get an audible sound. However, you would also get a lot of hiss because the Hi-Z microphone just doesn't have enough output level to work well in the Line Input jack. Plug the Hi-Z microphone back into its proper input, the microphone input jack on the Input Channel, using an adapter, or preferably, an impedance matching transformer, and things will work right again.

One common source of hiss is an analog tape machine, in which case the best solution is to use a tape noise reduction device, or to turn off the input when no signal is present. Another source of hiss is a broadcast or wireless microphone tuner/receiver, in which case you may get an improvement from a better tuner antenna.

Other Noises.

One (unfortunately very common) source of noise is faulty audio cables or connectors. A bad cable can make a loudspeaker sound like it is "blown" or it can make a microphone sound like a kazoo.

In fact, bad cables are so common that you should probably suspect them when just about any problem occurs in your system. If you suspect a bad cable, try replacing it. If the problem goes away, you have found the culprit. Sometimes, a bad cable may not be "bad" all the time, but may have an intermittent failure, that causes a problem when the cable is moved a certain way. Try shaking the cable to see if the problem gets worse (or better).

Troubleshooting A Sound System.

Repairing a sound system may require the skills of a trained technician. Troubleshooting and finding the problem is something almost anyone can do if they:

- 1) Know the block diagram of their system.
- 2) Understand what each component in the system is supposed to do.
- 3) Know where to look for common trouble spots.

Know Your Block Diagram.

A sound system block diagram tells you how the various components in the system are connected to each other and what happens to a signal as it flows through the system. Reading a block diagram is relatively easy (see the section entitled "Understanding Block Diagrams" for a review). Because the block diagram shows the way the sound system operates, it is extremely useful in the troubleshooting process.

Know What Each Component is Supposed To Do.

As obvious as it may sound, you can't tell whether a component is working properly or not unless you know what it's supposed to do in the first place! Thus, it's a good idea to keep instruction manuals on all components handy. Some "repairs" are as simple as repositioning a control knob or throwing a switch that someone has inadvertently changed.

Know Common Trouble Spots.

Cables and connectors are by far the most common sources of problems in audio systems. This is the best reason to keep lots of spares, especially of cables that are moved around a lot, like microphone cables. Other common trouble spots are fuses and circuit breakers, switches and controls that are in the wrong positions, and problems with house A.C. power.

Logical Troubleshooting.

The process of troubleshooting involves logical thought and methodical tracking down of a problem by the process of elimination. Logical thought processes come into play when a problem first occurs. If a single microphone suddenly goes dead, your logic tells you that the power amplifier probably isn't at fault. If, on the other hand your whole system is suddenly quiet, the power amplifier might be at fault, but it's not likely that all of your microphones have failed at once.

A methodical elimination process can track down the source of most problems very quickly. The idea is to find out what component (microphone, cable, mixer, amplifier, loudspeaker) is causing the problem, and to replace it, bypass it, or repair it.

During a performance, of course, bypassing or replacing a faulty component is the most likely cure since a repair might take up too much time. Your mixer is a good place to begin the trouble-shooting process because it has the controls for the entire system. If you hear a noise in the system, for example, look at your VU Meters, and Peak LED indicators. This alone may tell you that the noise problem is coming from one microphone.

Pull down the fader for that Input Channel. If the noise goes away, unplug the microphone and bring the channel fader back up. If there is no noise, great! Turn it back down, and then plug in another microphone into it, and bring the fader back up. If the new mic works well, you have eliminated the input channel of the mixer as the problem, and limited the problem to either the microphone or the mic cable. Try the suspect mic with a new cable, if it works OK, you have found the problem. If it doesn't, try a different mic with the new cable. If it works, go back to the original cable. If that works, you have eliminated all the causes of the problem except for the mic, and that mic is at fault.

If your entire system (all microphones) suddenly goes dead, again, check out your VU Meters and LEDs. If they are still active, then you know your system is working at least through the Mixer. Thus, some component further along in the system must be the culprit. Think through your block diagram at this point to find the next suspect component (One "component" that's often a problem is the house A.C. power in a device "upstream" in the signal path).

When possible, patch around suspect components, to see whether the problem is in the suspect component.

For example, a limiter or graphic equalizer can be completely removed from the system, and the system will still operate. Thus, if you suspect a specific device (or sub-section of your PX-2200), use a patch cable to bypass the device in question. For example, let's say something appeared to be wrong with one of the graphic equalizers or the power amplifier on your PX-2200.

First, check the switch on the graphic equalizer that selects where it takes its input signal (main left, mono sum, or monitor 1 for graphic equalizer A, or right main, mono sum, or monitor 2 for graphic equalizer B. If the switch is in the "wrong" position (not the one you want), flip it to the desired position. If the signal comes back, you have found your problem. If that has no effect, take a patch cord, and try patching from the desired mixer output (left or right main out, mono out, or monitor 1 or 2), directly to the power amplifier input (Amp A In or Amp B In jacks). If the signal comes back, then the equalizer is at fault.

Usually, no matter how bad the problem, as long as you have A.C. power, you can find a way to get something happening.

When the suspect component is necessary to the operation of the system, try to replace it with some other equivalent component. If you suspect a bad loudspeaker, for example, try switching your left and right loudspeakers or using a monitor loudspeaker temporarily in place of a main system loudspeaker. If you suspect your mixer, try running a tape machine directly into your power amplifier to make sure that the power amplifier portion of the system is still working.

"Repairs" may be as easy as replacing a bad cable or patching around a bad signal processor, or removing a faulty loudspeaker from the system. But, before you can repair a system, you must find the source of the problem, and that is what troubleshooting is all about.

Choosing and Using Pro Audio Microphones.

Types of Microphones.

There are three primary ways to classify microphones: by impedance, by element type, and by directional pickup pattern.

Pro audio microphones are either low impedance (Lo-Z) or high impedance (Hi-Z). A low impedance microphone will have a "source" impedance (see 'Impedance and Level Watching) of anywhere from about 50 ohms to as high as 600 ohms, but 150-ohms to 250-ohms is most common. A high impedance microphone will have a source impedance ranging anywhere from 1000-ohms to as high as 10,000-ohms (10k ohms) or greater.

Because of the problem of high frequency loss with Hi-Z microphones using long cables, most pro audio microphones are low impedance. In addition, because of the superior noise rejection of a balanced line, most pro audio microphones have a balanced output (as opposed to most Hi-Z microphones, which are unbalanced).

There are many different ways to convert sound energy to electrical energy, and the portion of a microphone that accomplishes this task is called the "element". For pro audio, most microphones use either a "dynamic" or a "condenser" element. Dynamic microphones use a moving coil, attached to the diaphragm and immersed in a magnetic field, to convert sound to electrical energy.

Condenser microphones use a pair of electrically polarized plates, one moving, one fixed, to convert sound into electrical energy. Condenser microphones require some kind of external power source, either a battery or "phantom power" from a mixer (your PX-2200 Mixer supplies 48 volt phantom power, which is the standard voltage for pro audio use).

The directional pickup patterns of microphones fall into two general categories: omni-directional and directional. Ideally, the frequency response of an omni-directional microphone is very uniform at any angle away from the front of the microphone. The pickup patterns of directional microphones vary with their design. The most common pro audio directional microphone has a "cardioid" pickup pattern (somewhat like a heart shape rotated into 3 dimensions). Omni-directional and directional microphones are available with either dynamic or condenser elements, and in both Lo-Z and Hi-Z impedances.

Choosing Microphones.

Dynamic microphones are noted for their ruggedness, their reliability and their ability to handle very high sound pressure levels without distortion. Condenser microphones are somewhat less rugged, and may distort when presented with extremely high SPL levels.

Condensers are not necessarily inferior, however, for their sonic characteristics might be described as more open, or "brighter" than most dynamic mics. Newer condenser microphones are, however, are more rugged, and will handle higher SPL levels than earlier models. Thus, your choice can be based on pickup pattern and subjective sound quality.

The cardioid pickup pattern is valuable in pro audio because a cardioid microphone rejects sound that comes from behind the microphone (like audience noise or leakage from other instruments). Because of this rear-rejection, a cardioid microphone is less prone to feedback (howling) caused by stage monitor loudspeakers feeding back into the rear of stage microphones.

Cardioid microphones, on the other hand, may have non-uniform sound quality as you move off-axis. That is, if you talk into the side of a cardioid microphone, the sound level will decrease, and the sound quality will change. This is undesirable, especially for microphones that need to pick up more than one sound source (like a mic used for a pair of vocalists, or a choir mic in a house of worship). This effect varies greatly among brands and models of microphones, so don't automatically reject a cardioid mic for a multi-source application, just check it out carefully.

The sound quality of a cardioid pickup microphone may also vary with distance away from the microphone. This is known as a "proximity effect" and it results in more bass response (a warmer sound) as a singer moves closer to the microphone. In some cases, this can be an asset to a singer who knows how to use this effect to their advantage, to add a sense of "intimacy" (like talking lowly into someone's ear). For someone who doesn't understand microphones, however, proximity effect could cause unwanted boominess in the sound. (Proximity effect is also discussed in the section entitled "The Input Channel EQ Controls").

Another aspect of a microphone's sound quality is known as presence. A microphone with a lot of presence probably has a slight boost in the mid to high frequencies to improve the clarity of the sound.

Presence can enhance the sound quality of many vocalists and can increase intelligibility in speech-only systems.

Omni-directional microphones have much more uniform sound quality as you move around the mic than do cardioid microphones. They may, however, be more prone to feedback, and cannot reject noises coming from the rear of the microphone. One way to overcome these problems is to "work" the mic very closely. That is, the performer should sing or play their instrument very close to the microphone at all times. That way, the mixer operator can reduce the level of the fader on that Input Channel, which helps reduce feedback and noise pickup. The sound quality of an omni-directional microphone also does not vary appreciably as you move away from the microphone. This can be an advantage. Again, however, the best way to judge a microphone's sound quality is to try it out yourself. Also remember that no two mics are the same (even between the same model from a single manufacturer), and mics should also not be considered as "good" or "bad", except as they apply to a given instrument or vocalist. Your microphones are the paints on your sonic "artist's palette". Learn what they sound like, their strengths and their weaknesses, and use them selectively to paint your masterpiece.

Three excellent references for more information on microphones are "Making The Connection: The Fender Pro Audio Primer" by Tom Butler (Available from your Fender Pro Audio Dealer), "The Microphone Handbook" by John M. Eargle, published by ELAR Publishing Company of Plainview N.Y., and "Microphones," a short text available from Gotham Audio Corp. 741 Washington St., New York, NY 10014.

Using Direct Boxes And Instrument Pickups.

A direct box is a device that splits the signal from an electric guitar, or any instrument with a high impedance pickup or output, and sends it to both the normal instrument amplifier, and also converts it to a balanced low impedance signal (like a low impedance balanced microphone), and sends it to the microphone inputs of a mixer. The direct box usually includes a transformer or, in an active direct box, a preamplifier, to convert the high-impedance, unbalanced instrument pickup signal to a balanced low-impedance signal. Since this signal is about the same level as a low-impedance microphone, you can plug the output from most direct boxes into the Lo-Z microphone input jack on your PX-2200 Mixer. The signal sent to the instrument amplifier is unchanged from the normal signal. Other instrument pickups include their own preamplifiers. The output of these preamplifiers may be low line-level, which means that you can connect it to the 1/4" line input on your PX-2200 Mixer. Direct boxes, instrument pickups and their associated preamplifiers are sometimes called "microphone substitution devices" because they are sources whose output level is nearly the same as a microphone.

Microphone Pickup Patterns

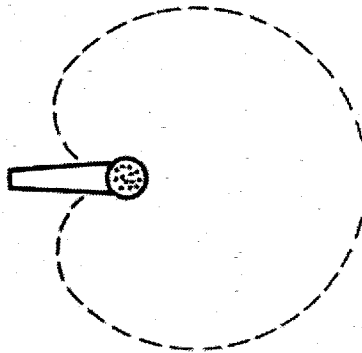

Cardioid pickup pattern microphones attenuate sound from the rear.

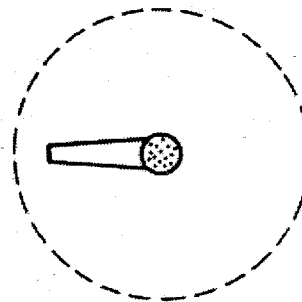

Omnidirectional pickup pattern microphones pick up sound uniformly from all directions.

Other Sources.

Most other sources, from synthesizers to CD players, or tape machines to tuners, can be connected to either the unbalanced 1/4" line inputs, the effects and/or Aux. returns, or the tape input jacks of your PX-2200 Mixer.

Phonograph turntables, of course, require an "RIAA" phono preamplifier to correct for a built-in curve introduced when an LP is cut. Several manufacturers make small, separate phono preamplifiers which usually have low line-level outputs. Or, you can use the "preamp outputs," "tape outputs" or "auxiliary outputs" on your hi-fi preamplifier, receiver, or integrated amplifier.

Using Special Effects Devices.

Special effects devices may be connected to either the main or monitor mixes (via the Effects and/or Aux. send outputs and the Effects and/or Aux. returns), or into an individual input channel (via the Input Channel Insertion jack). These connections were discussed earlier in this manual. The most common effects include reverberation, instrument effects (fuzz, phasing, flanging, etc.), delay lines, expanders, and the various noise sources used in live theater.

A complete digital reverberation and time effects section is built into your PX-2200 series mixer (unless you have a PX-2208 (non-D model), in which case a spring-type reverberation system is included).

If the device is an instrumental special effect, you may only want to use it on one instrument.

In that case, you would use it through the Insertion jack on one of the Input Channels of your PX-2200 Mixer (or connect it directly to the instrument output itself or through an effects loop on your instrument amplifier). If the device is meant to enhance a voice, then you would again, probably use it on a single Input Channel via the Insertion jack.

Some effects, however, like reverberation, will probably be used on a mix of selected instruments and voices. Use these through the Effects mix.

Using Compressors, Limiters, Noise Gates, & Expanders.

Actually, limiters and compressors are two versions of the same device. In fact, many such devices are called "compressor/limiters."

An "expander" is a similar device.

All three devices monitor the signal level and change it (like an automatic volume control) in some pre-determined way.

A compressor reduces the level of high-level signals and increases the level of low-level signals. In other words, it reduces the "dynamic range" of the signal. Compressors are used by background music suppliers to keep the level of their music nearly constant. This allows the music in a department store, for example, to always be loud enough to hear (above crowd noise) but never so loud as to be annoying (or thoroughly irritating, depending on your orientation). You could use a compressor for the same purpose in mixing a quiet group for a hotel lounge. They may also be used artistically, to bring an instrument forward in a mix, making it appear louder by compressing its dynamic range, and making it stand out from other signals.

Compressors are also useful for tape recording. The dynamic range of live music must be reduced to fit the dynamic range capabilities of a tape recorder, and a compressor can be used for this purpose. For analog tape recording, special noise reduction devices, like those made by Dolby and DBX and others are probably a better choice for this purpose, however.

A limiter operates like a compressor, but it reduces the level of high-level signals that go above a predetermined threshold point, but it does not affect low level signals below that predetermined threshold. While compressors are operating most of the time, a limiter only operates above the selected threshold. That is, the limiter begins to reduce the signal level only when it exceeds some preset level.

Limiters are used by radio stations to avoid over-driving their transmitters. Limiters are also used extensively in pro audio. They may be used on an individual microphone to automatically ride gain on a vocalist, or they may also be used to keep the audio signal from overdriving a power amplifier (overdriving a power amplifier can cause clipping distortion and can even cause damage to the power amplifier and loudspeakers).

The DeltaComp™ circuitry in your PX-2200 Mixer is a very sophisticated form of a limiter, preset to help you avoid overdriving the power amplifiers in your PX-2200 Mixer. External limiters are probably the best way of protecting your external power amplifiers and loudspeakers from damage and are an excellent way to help you avoid clipping distortion.

An expander actually increases the level of high-level signals and reduces the level of low-level signals. Thus, an expander increases the dynamic range of a signal. Expanders in pro audio are used primarily for special effects. An expander, used improperly, could present a danger to your system since it could increase high-level peaks to the point of clipping.

Noise Gates are also extensively used in pro audio. A noise gate is a device much like a "squelch" control on a CB radio. When the signal falls below a certain "threshold", the noise gate turns the signal off, automatically "muting" the signal. This may be used to turn off unwanted microphones to help prevent feedback, or as an effect, such as on a output of a reverb system to shorten the decay time of the system.

Equalization.

What Do We Mean By "Equalization"? The term equalization originally meant "to equalize the frequency response of a sound system to match a room". The term equalization, however, now applies to just about any process that changes the frequency response of a signal. The Input Channel Equalization controls, for example, would probably be called "tone controls" on a hi-fi product. In pro audio, however, they are called "Equalization" controls.

A "graphic" equalizer is so-called because the position of its sliders form a curve, like a graph of the frequency response.

Using Equalizers

As we discussed in "The Input Channel Equalization Controls", the Input Channel Equalization controls are used to change the tonal character of an individual voice or instrument. The two assignable Graphic Equalizers on your PX-2200 mixer (or an external graphic equalizer) are used to affect the frequency response of an entire mix to compensate for room acoustics, for example.

Elaborate test equipment, including pink noise generators and real-time analyzers are available to aid in the process of room equalization. The instruction manuals that come with a real-time analyzer usually explain the process of room equalization or you can purchase one of several books on the subject including "Sound System Engineering" by Don and Carolyn Davis, published by Howard W. Sams.

So-called "narrow-band" equalizers or "notch filters" are sometimes used to help stop feedback (howling) in a system or the ringing that comes just before feedback.

Using equalizers to help control feedback is covered in more detail in the section entitled "Dealing with Feedback, Hum, Hiss, and other Noises".

An equalizer of any type is a powerful tool. Equalization can, indeed, help compensate for undesirable room acoustics. An equalizer can, within limits, be used to compensate for poor loudspeaker frequency response (graphic equalizers or notch filter can be used, again within limits, to control feedback).

And, of course, tone controls like the Input Channel Equalization controls on your PX-2200 Mixer, can be used to enhance an individual instrument or voice.

(So-Called) Room Equalization.

At one time, it was thought that an equalizer could actually reduce reverberation in a room (it can't). Equalizers were also thought of as the answer to controlling feedback (they can help but are not a cure-all). We now know that room reverberation can only be affected by acoustic treatment and that feedback has complex causes that are not all related to system frequency response.

You can, however, use the two assignable Graphic Equalizers on your PX-2200 Mixer to help compensate for poor room acoustics. For example, most highly reverberant rooms have their worst reverberation in the lower frequencies. Reducing the level of the lower frequencies on your Graphic Equalizer may help the system sound less "boomy." Try to avoid high SPL levels in a reverberant room, too. In many rooms, lowering the overall SPL level will help reduce the apparent reverberation.

At the opposite end of the reverberation problem (too little reverberation as opposed to too much), some hotel lounges have so much carpet, acoustic tile and padded furniture that they absorb reflected sounds, and thus sound extremely "dead". Adding a little high-frequency boost with your PX-2200 Mixer's Graphic Equalizer can bring some life back into the sound (use the PX-2200's internal digital reverberation system, too!).

Equalizers and Loudspeakers.

Most non-bi-amplified loudspeakers have some amount of equalization designed into their crossover networks. The purpose of this equalization is to help smooth their frequency response. These loudspeakers seldom require additional equalization to improve their frequency response. The same applies to those loudspeakers which come with an external, active equalizer meant to be installed between a mixer and power amplifier. The equalization in that active equalizer is all you should need. Adding additional equalization to these loudspeakers to, for example, increase their bass response, may work very well at low power levels. At higher power levels, however, this kind of additional equalization may result in amplifier clipping and even loudspeaker damage.

Thus, if your loudspeaker system always seems to need additional low-frequency (boost) equalization, consider adding a sub-woofer. If your loudspeaker system always seems to need additional high frequency (boost) equalization, consider adding a super-tweeter instead.

Bi-amplified or tri-amplified (etc....) systems, designed from separate components, may need some equalization to smooth out their frequency response.

In most cases, you'll need a reduction of some frequency bands. However, if more than 3 or 4 dB of boost seems necessary, your loudspeaker system may need additional (or different) components, or more probably, your electronic crossover is set up incorrectly.

Choosing and Using Loudspeakers.

Types of Loudspeakers.

There are two basic ways to purchase a loudspeaker system: as a prepackaged system, and as a component system.

Pre-packaged systems are usually designed and built in a single enclosure by a manufacturer. Most pre-packaged systems are designed for low to medium SPL applications. In groups, however, they may be useful in medium to high SPL applications. Some pre-packaged systems are designed primarily for portable usage, and come with handles, corners, and a protective finish. Others are designed primarily for permanently installed systems, and come in furniture finish or neutrally finished wood enclosures. Because they are manufactured on an assembly line, pre-packaged systems are usually a better value per dollar spent.

Component systems are constructed from individual woofers, midrange loudspeakers, and tweeters and may be assembled by a dealer or knowledgeable end user. A suitable component system can be assembled for any permanent or portable application. Because they are custom assembled, a component system may cost more than an equivalent pre-packaged system (unless you do much of the work yourself).

Component systems, however, can be custom designed to fit the exact requirements of your application.

Two-Way And Three-Way And So On.

A few loudspeaker systems are "one-way", that is, they use only one type of loudspeaker to cover the full range of audio frequencies.

Column speakers are often "one-way"; so are some of the loudspeakers which use an external, active equalizer (such as many models from the Bose Corporation). Most loudspeaker systems, however, are two-way, three-way, or more (multi-way). That is, they use two, three, or more different types of components to cover the audio frequency range.

Two way systems are common in permanent installations and speech-only systems. Some two-way systems are designed for low-to-medium SPL entertainment (music and voice) applications. Three-way and multi-way systems, however, are more common for medium and high SPL entertainment systems, and four-way and even five-way systems are used for some high SPL systems.

Woofers and Tweeters .

Most woofers (low-frequency loudspeakers) are cone type loudspeakers. Smaller systems may use 8", 10", or 12" diameter loudspeakers as woofers. Mid size systems may use 12" or 15" diameter woofers, and large systems almost always use high power 15" or 18" woofers. A small diameter woofer may be able to produce very low frequencies quite well, but a larger diameter woofer will, in most cases, be able to produce those same low frequencies at higher SPL levels.

In trade, the smaller woofers usually have better midrange response which makes them a good choice for two way systems (which have no separate midrange component).

Woofers may be installed in simple, sealed wooden enclosures (often called infinite baffle enclosures). A vented or ported bass reflex enclosure has a hole(s) or tube(s) in the front baffle, which can improve the low-frequency response of the woofer (compared to an infinite baffle enclosure). Some woofers are "horn-loaded", that is, they are placed behind a low frequency horn which is usually a part of the enclosure. Horn-loading can increase efficiency and provide a measure of control over the woofer's dispersion at higher frequencies (above 200 Hz.). In order for a horn to work at low frequencies, however, it must be very large and the horns that are used with most woofers actually work well only in the midrange. Thus, horn loaded woofers are most often seen in two-way systems where the woofer covers at least part of the midrange frequencies. Horn loading is often combined with a vented enclosure. In this case, the horn section aids the woofer's performance in the midrange, and the vented enclosure aids the woofer's performance in the low frequencies. This type of system is sometimes called a vented horn.

Tweeters (high frequency loudspeakers) come in several varieties. Hi-fi and low-level pro audio loudspeaker systems sometimes use small cone loudspeakers or dome-type loudspeakers for tweeters. Almost all medium to high SPL level pro audio loudspeaker systems, however, use some form of "compression driver" and horn to cover the high frequencies.

A "compression driver" is a device that works much like a cone loudspeaker, that is, it has a magnet, voice-coil, and a cone or, more likely, a dome. A compression driver, however, has a device known as a phase plug between the dome and the output of the driver, and a compression chamber behind the dome, from whence comes its name. Compression drivers are usually very efficient.

Typically, a compression driver will produce from 4 to 10 times as much sound per electrical watt as a cone type loudspeaker. It would be very difficult, however, to design a compression driver to work well at low frequencies, so compression drivers are used as midrange and high frequency components.

A compression driver must be connected to a horn, or in some cases, a lens (which performs much the same function as a horn). The horn loads the driver in much the same way that an enclosure loads a woofer. This horn-loading makes possible the efficiency of the compression driver in the same way that horn-loading a woofer can improve its efficiency. The horn also helps control the dispersion of the sound.

There are several types of horns. Exponential horns come in two varieties: straight and radial. Straight exponential horns are low cost, small in size (for a given frequency range), and usually have a pleasant sound quality but may become very beamy (narrow dispersion pattern) at high frequencies. Radial exponential horns are slightly higher in cost,

about the same size (for a given frequency range) as straight exponential horns, and usually have a pleasant sound quality. The dispersion pattern of a radial horn in the horizontal plane is usually fairly consistent over a wide frequency range. The dispersion in the vertical plane, however, usually narrows at the high frequencies in a similar manner to a straight horn.

Radial horns, are sometimes called sectoral horns. Although it is sometimes mis-used, the term sectoral means that the horn is made from a sector of a sphere. Sectoral has nothing to do with the number of sections in the horn (see Multi-Cell horns below). Straight horns are sometimes used in packaged loudspeaker systems, but radials are a more common choice. Because a well designed straight or radial horn usually has a very pleasing sound quality, they are often used in entertainment (music plus voice) oriented loud speaker systems.

Multicell horns are actually made from groups of narrow-coverage angle straight exponential horns. Multicells were an early, and reasonably successful, attempt to overcome the high frequency beaming problem of straight exponential horns. Multicells are primarily used in voice-only systems, and because of their good dispersion control, they are often used in highly reverberant rooms (Good dispersion control means you can point the sound at the audience and do a good job of keeping it away from the walls and ceiling).

So-called "constant directivity" horns have very good dispersion control in both the horizontal and vertical planes, over a wide frequency band. Some constant directivity horns have very good sound quality.

Unfortunately, for a given frequency range, true constant directivity horns tend to be somewhat larger than other horn types. A constant directivity (or CD horn) combines the best of both a radial and an exponential horn.

In a two-way system, the woofer and tweeter share the midrange frequencies. In a three-way or multi-way system, a separate component is used to cover the midrange. That component may be a compression horn and driver, or it may be a cone type loudspeaker, depending on the frequency range it must cover and its SPL output.

Some systems include sub-woofers or super-tweeters or both. A sub-woofer is designed to extend the low frequency response of a loudspeaker system, or to improve the SPL capabilities of a system in the lower frequencies. Sub-woofers are usually 15" or 18" loudspeakers in vented bass reflex or bandpass style enclosures, although some are also horn loaded. Super-tweeters are designed to extend the high frequency response of a loudspeaker system. Sometimes, a compression driver and horn are used as a super-tweeter. "Ring-radiators," "piezo-electric" tweeters, and other devices are also used as super-tweeters.

Choosing Loudspeakers.

Besides the obvious question of budget, here are a few other things to consider in making a choice of loudspeakers:

1) Power Handling. The loudspeaker system should be able to handle the full power output of your power amplifier (150 to 300 watts per channel for your PX-2200 Mixer) for an extended period of time over the full rated frequency range of the loudspeaker.

2) Frequency Range and Response.

The loudspeaker's response should be smooth over its intended operating range. If your system will be used primarily for voice, you can choose a loudspeaker system whose low frequency response is limited to as high as 70 or 80 Hz. If you must reinforce an entire musical group, especially a popular musical group, the system's low frequency response should extend down to about 40 Hz.

3) Sensitivity. This is a measure of the loudspeaker's efficiency. It tells you how many dB SPL the loudspeaker will produce at a given distance from the loudspeaker when the input power is a certain number of watts. High sensitivity is an advantage because it not only increases maximum SPL output capabilities, it also improves headroom. Remember that a decrease of only 3 dB in sensitivity means double the amplifier power needed to maintain the same SPL!

4) Coverage Pattern. In a pre-packaged system, you will usually get a short-to-medium throw coverage pattern (about 90 degrees horizontal by 40 degrees vertical). In a component system, you can choose several mid and/or high-frequency horns with different coverage patterns so that you can have long-throw, medium-throw, and short-throw devices. Long-throw horns are usually 2" exit diameter 40 degrees horizontal by 20 degrees vertical, and are usually only needed in large concert systems and permanently installed systems.

Medium throw horns are usually 60 degrees horizontal by 40 degrees vertical, and may have either a 2" or a 1" exit diameter. Medium throw systems are useable in many portable as well as permanently installed systems.

Short throw horns are usually 90 degrees horizontal by 40 degrees vertical, with a 1" exit diameter, and are used to reach the front of an audience, or may be used to cover an entire audience in a small portable system.

5) Sound Quality. Only your ears can tell you the answer to the all important question: How does it sound? It's an entirely subjective evaluation and that means that your own personal tastes play an important part. That's the way it should be, of course.

In a sense, the sound system is your instrument, and it should sound like you want it to sound. Yet your goal should not necessarily be to radically alter the sound of a performance, but to reinforce and, to some extent, to subtly enhance the sound of a performance. Your subjective evaluation of the sound quality of a loudspeaker system, then, should be based on how well you believe that loudspeaker system will accurately reinforce your performance. You must be familiar with the way your performance sounds without reinforcement to judge the accuracy of a loudspeaker system. In addition, you should do your listening tests with live sources if at all possible. Recorded music of any kind, especially if played from a cassette machine or tuner, hides many defects in a loudspeaker system.

Live music, or even a simple live microphone test, because of its increased dynamic range and transients, reveals the true nature of a loudspeaker system. If, on the other hand, you're buying a set of loudspeakers for disco use, by all means, evaluate them with recorded music!

Using Loudspeakers.

The "one on each side of the stage" approach can work quite well for a portable system. In permanent mono installations, however (except in very low-ceiling rooms), a single loudspeaker "cluster" usually works better than a pair of widely separated loudspeakers. The reason is the "phasing" problem discussed in the section on microphones. Here are some additional tips on loudspeaker usage:

1) Keep Voice Coils in Line. When stacking loudspeakers, try to keep their voice coils lined up in a vertical line. This will help minimize those "phasing" problems.

2) Stack Vertically, not Horizontally. Whenever possible, stack two loudspeakers on top of each other, not side by side. Again, this helps minimize phasing problems.

3) Keep High-Frequency Components Together. When stacking two of the same kind of packaged loudspeaker system, turn the top one upside down so that the horns are close together. This can improve the "throw" of the stack in the high frequencies.

Line Level Input (keyboard, sequencer, drum machine, line level audio gear)

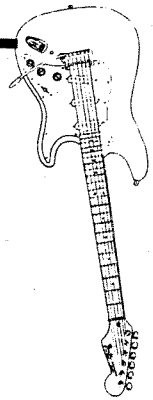
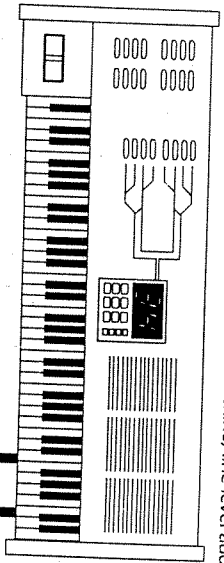

Guitar Out To Effects Device Input
Effects Device Out To Line Inputs

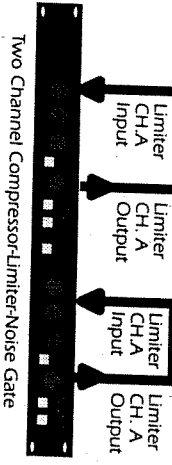
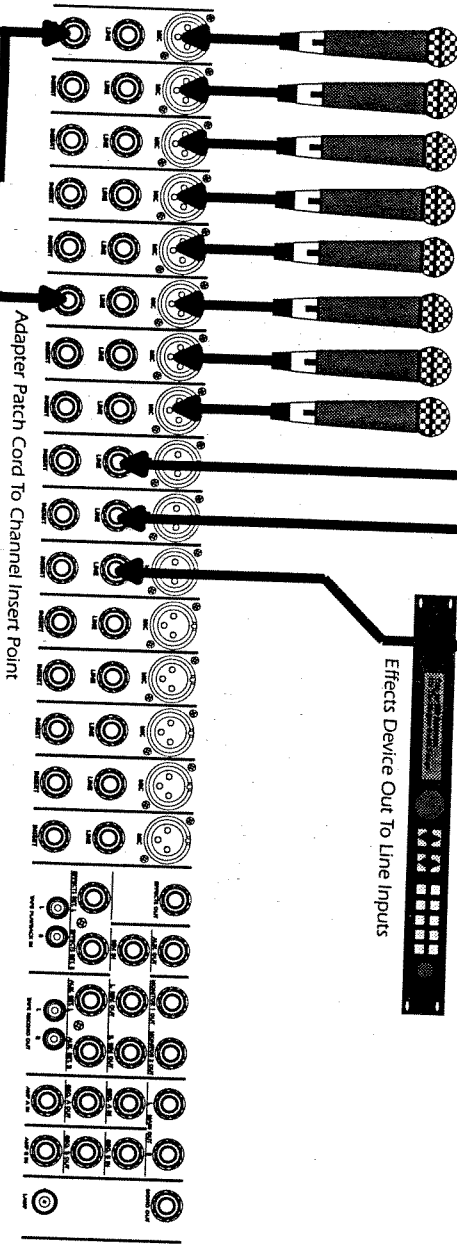

Graphic Equalizer Assignment Switch
(Both Graphic EQ A and Graphic EQ. B)
Set To The Center Mono Position

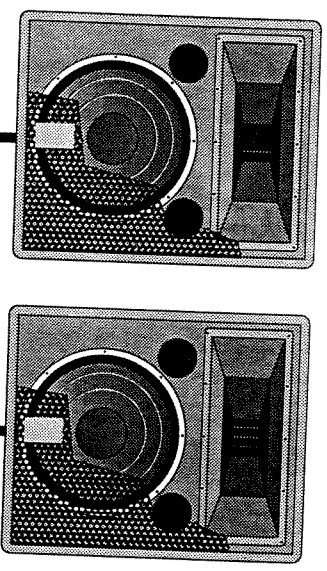
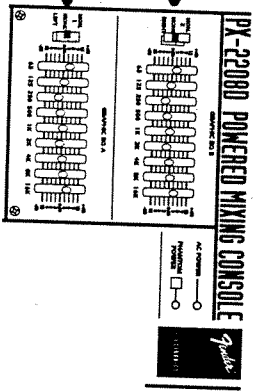

Channel A
Amplifier Output

Channel B
Amplifier Output

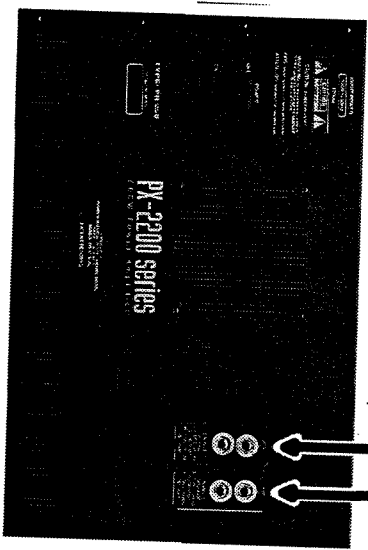

1 EXAMPLE ONE: A SMALL MONO P.A. SYSTEM

Line Level Input (Keyboard, sequencer, drum machine, line level audio gear)

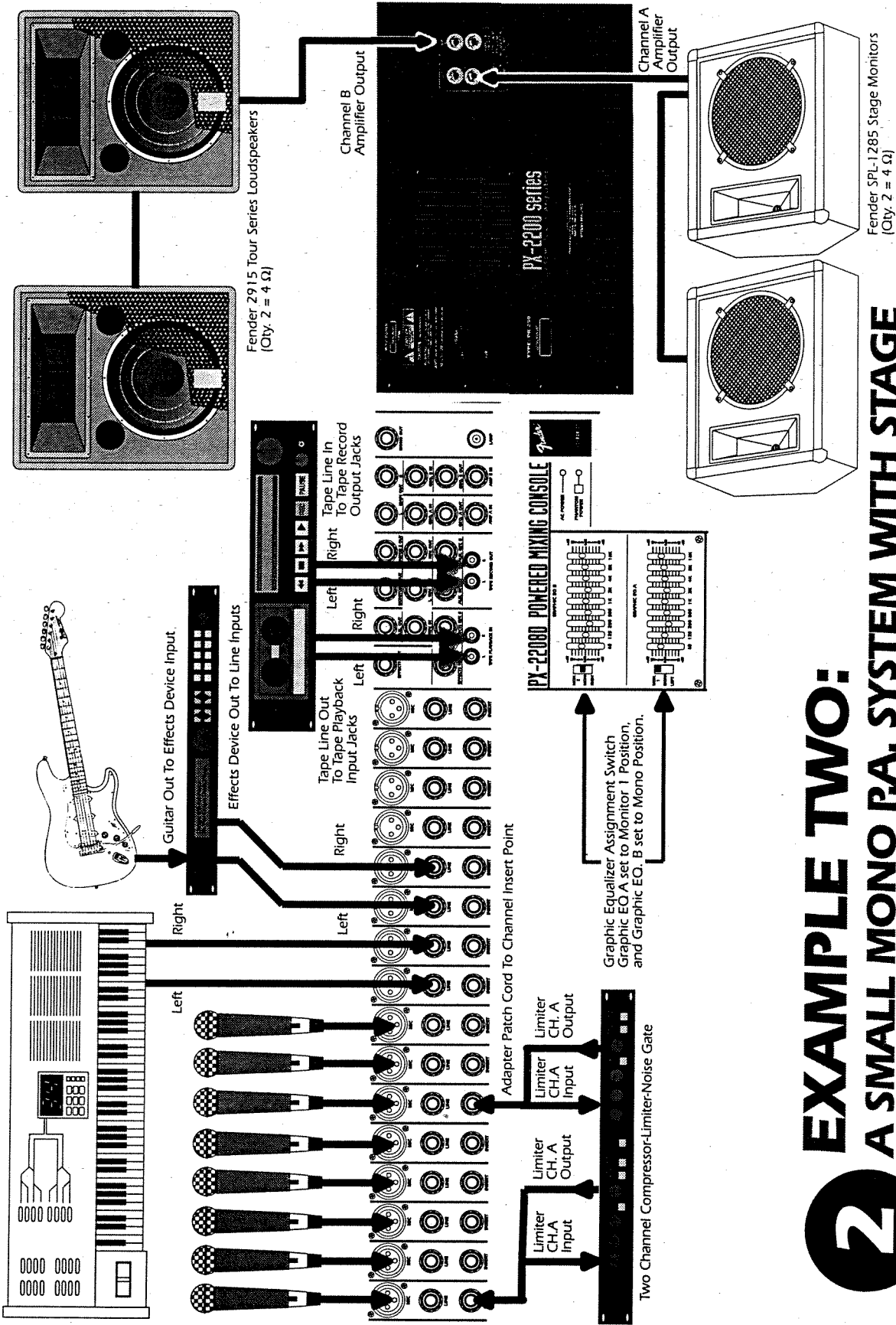

EXAMPLE TWO:

A SMALL MONO PA. SYSTEM WITH STAGE MONITORS AND A STEREO RECORDING MIX.



Line Level Input (keyboard, sequencer, drum machine, line level audio gear)

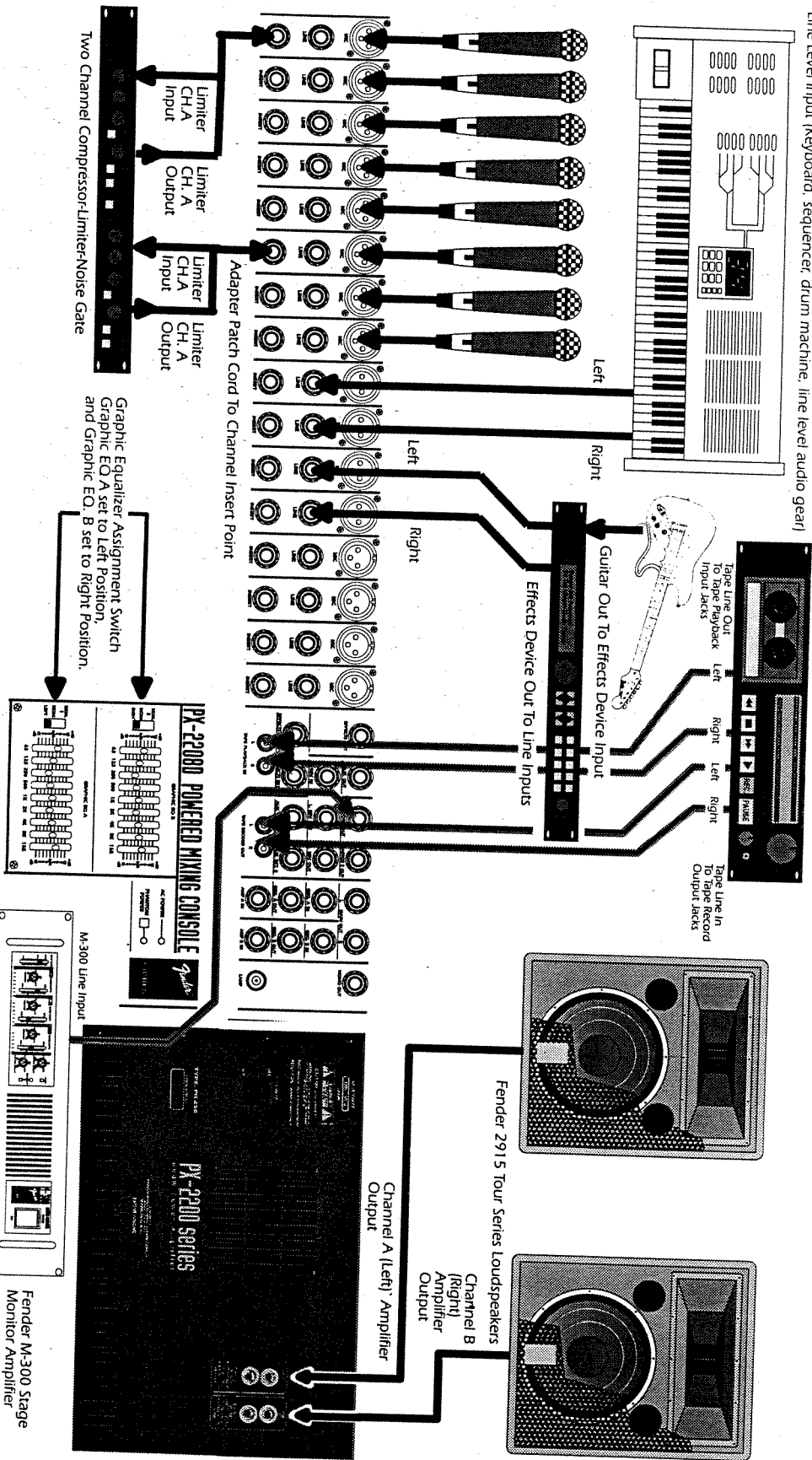

EXAMPLE THREE:
A Small Stereo P.A., With An
External Monitor System,
And A Stereo Recording Mix.

3

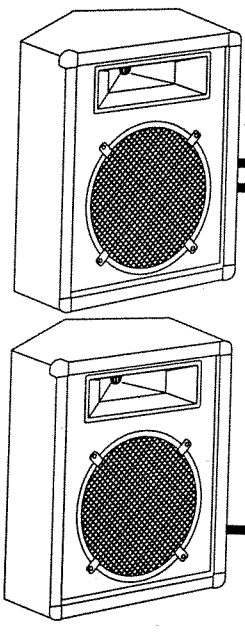

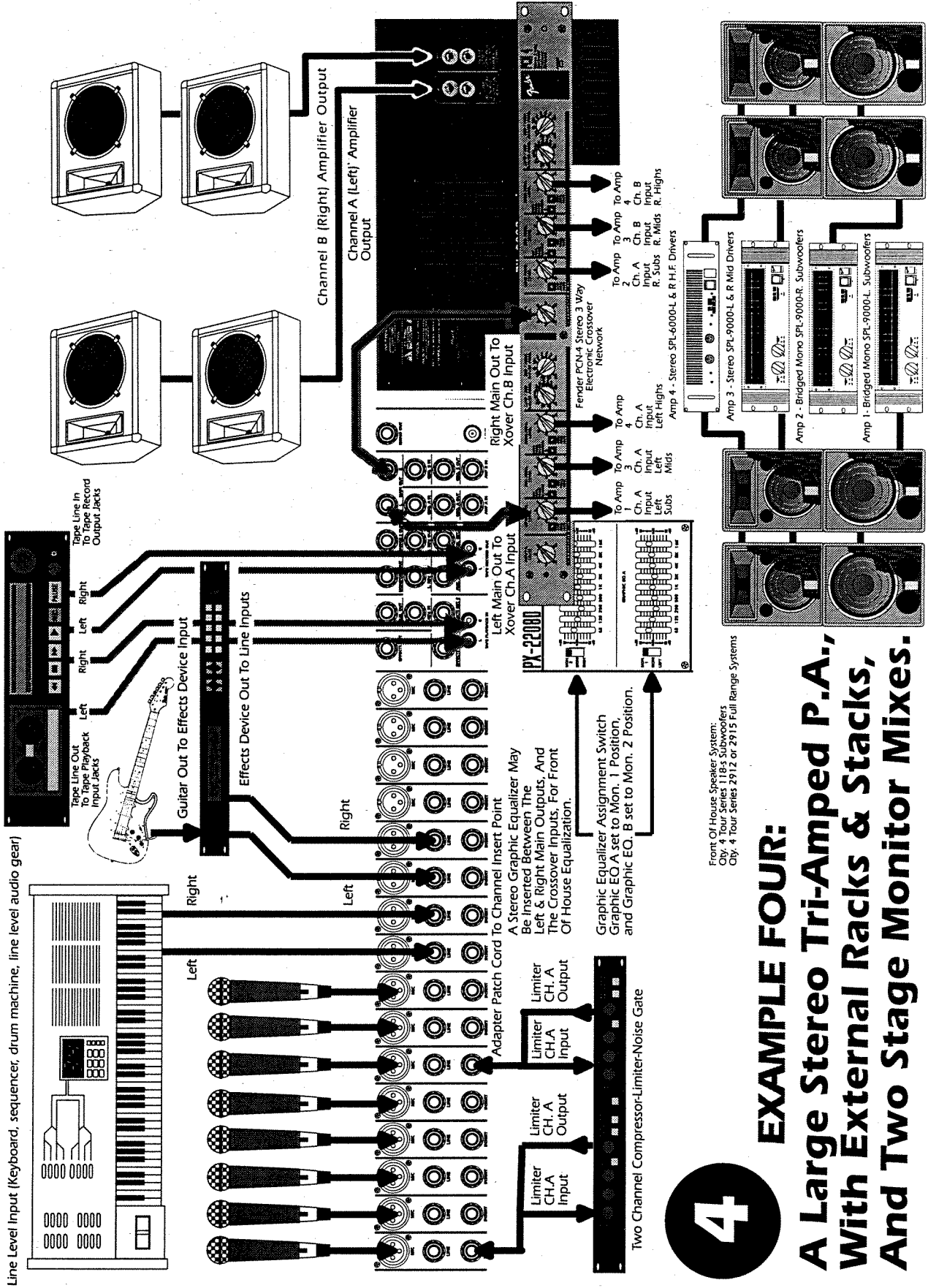

Front of House Speaker System:
 Qty. 4 Tour Series 118-S Subwoofers
 Qty. 4 Tour Series 2912 or 2915 Full Range Systems

4

EXAMPLE FOUR: A Large Stereo Tri-Amped P.A., With External Racks & Stacks, And Two Stage Monitor Mixes.

Line Level Input (Keyboard, sequencer, drum machine, line level audio gear)

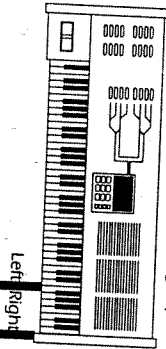

Input Channel Insert Points (see wiring of adapter plug below) Used As Direct Outputs And Routed To Multi-Track Recorder Through Eight One Through Eight

Monitor 1 Mix Output: Used To Feed A Mix From Multiple Microphones To One Or More Multi-Track Recorder Inputs. Used To Taking A Direct Feed For Each Track.

Stereo Middown Deck: Cassette, DAT, or DAW

Main Output (L&R) To Middown Deck Line Input Jacks (L & R)

3-Conductor Phone Plug To Mixer Front Panel Headphone Jack In Position For Use The Bull In Position For Maintaining Solo Capabilities. This Is Plugged Into Either The SEND Or The PWR. Amp. Inputs.

Control Room Monitor Loudspeakers

***Important Note:**
When Using The Headphone Output Jack To Feed Stereo Amps For Control Room Monitoring, Turn The Level All The Way Down, And Bring Up To The Desired Level. This Is A Very HOT Output!

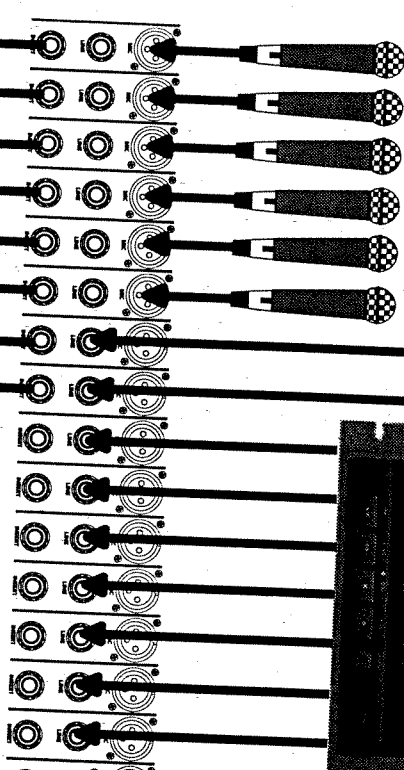

Graphic Equalizers May Be Used As Control Room Monitor EQ's. Or For More Extensive Input EQ's. The Channel Insert Points Are Used With The Out Jacks When Used With The Assignment Switch Does Not Matter. Since The Normal Signal Flow Is Interrupted.

Input Channel Insert Points Used As Direct Outputs (See wiring of adapter plug below). One Through Eight.

Insert Signal Processing (Compressors, Limiters, Equalizers, Noise Gates) Between Insert Point And Multi-Track Recorder Inputs As Required For Tracking Or Overdubbing With Effects.

5

EXAMPLE FIVE: Eight Track Recording & Mixdown, Using The Channel Insert Points As Direct Outputs

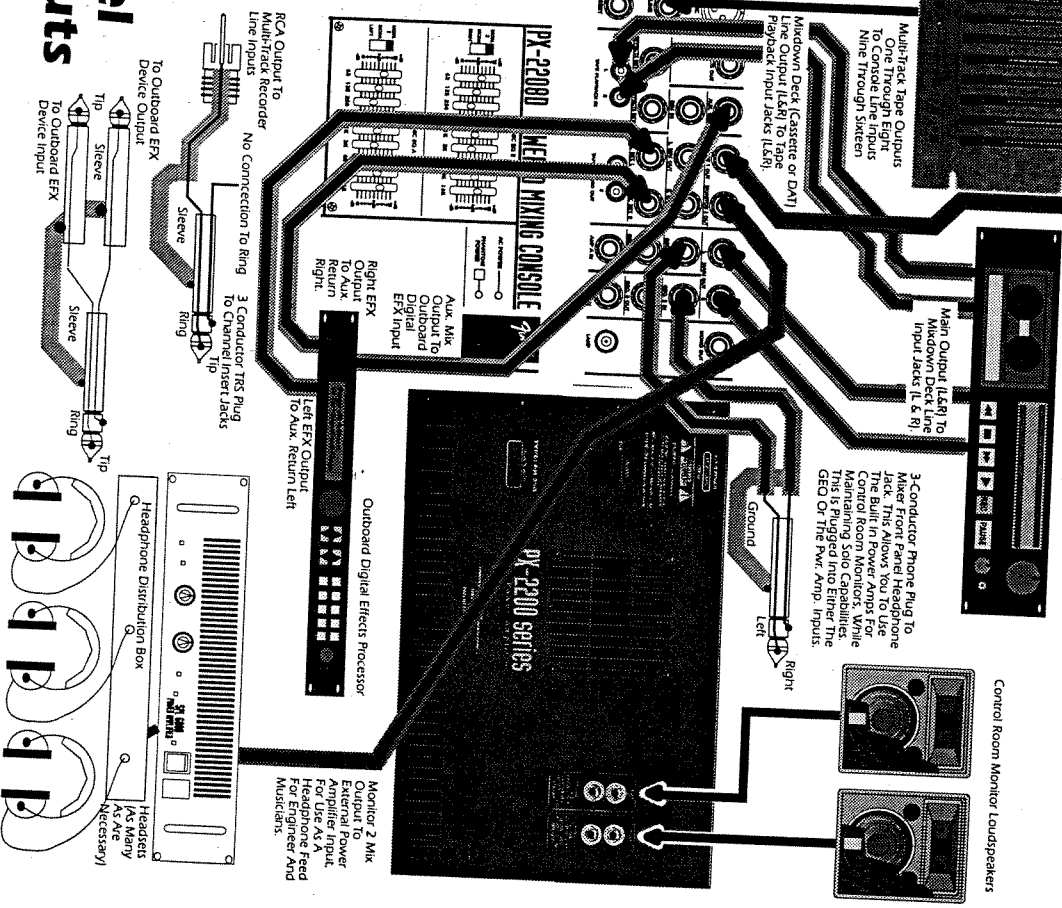

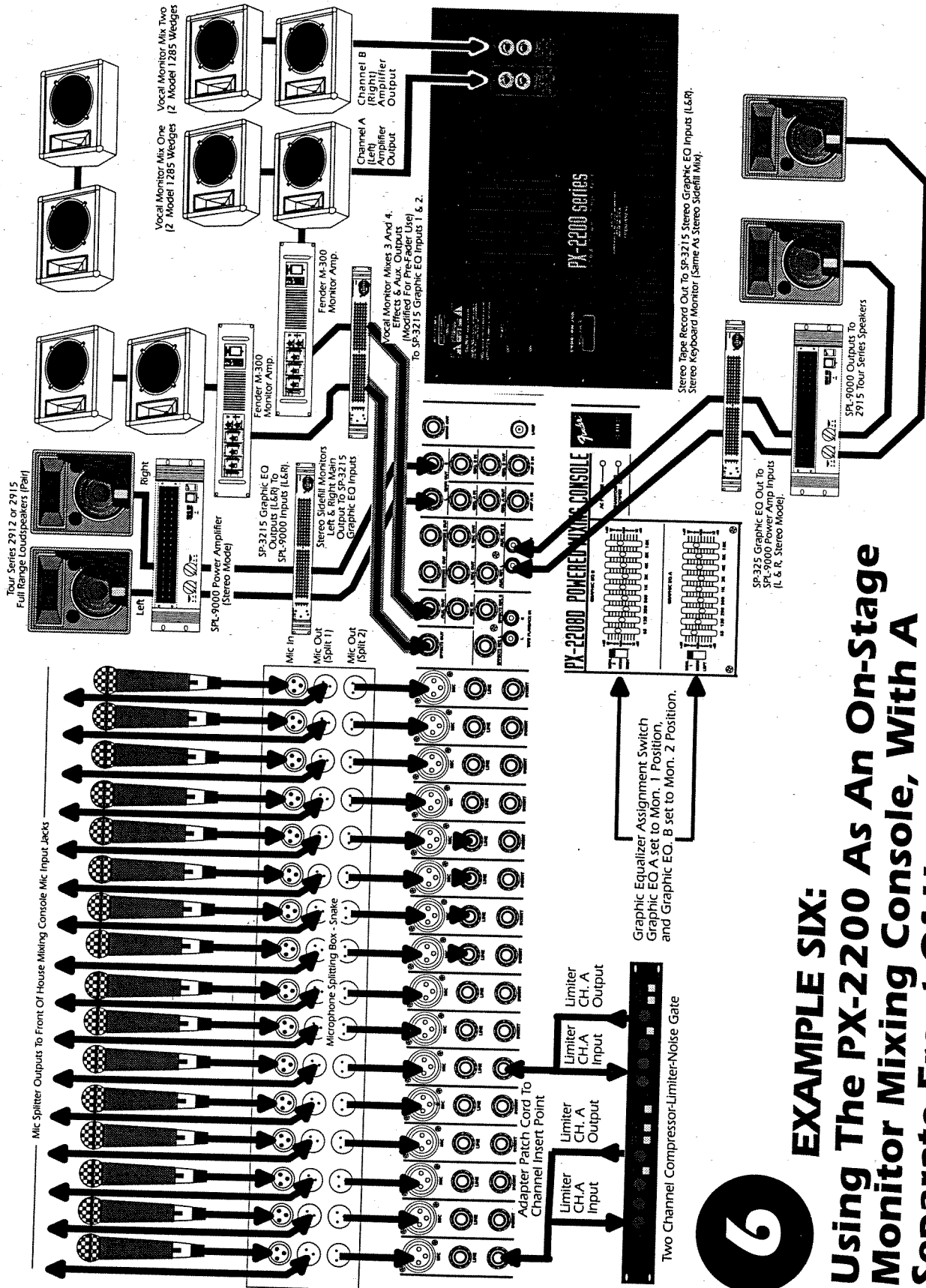

Specifications.

We publish these specifications to help you understand the features and performance of your Fender PX-2200 Series Mixer. There are separate sections for Models PX-2208 and PX-208D, and another section for the models PX-2212D and PX-2216D.

Refer to the SPECIFICATIONS section for information on the performance and features of each mixer.

Refer to the INPUT IMPEDANCE AND LEVEL and OUTPUT IMPEDANCE AND LEVEL charts for information about the various input and output connectors.

The MAXIMUM VOLTAGE AMPLIFICATION chart contains information about the gain (more accurately amplification) from any input connector to any output connector. Using the numbers in this chart, you can determine the level at any output connector from a source at any input connector. Just add the dB Amplification given in the chart to the dB level of the source.

This output level assumes that all faders and the Trim control are at their maximum positions. To find the output level with faders or Trim at some lower position, subtract the dB number on the fader or Trim control from the sum of the source level and the dB amplification number. These numbers are approximate and may vary due to slight differences in control accuracy.

The 0 dB Reference.

When we use the term dB to indicate a voltage amplification factor (gain), no reference is implied. 101 dB of Voltage Amplification means that if you take 20 times the Log (base 10) of the output voltage divided by the input voltage, the answer will be 101

dB.

When we use the term dB to indicate a voltage level, we are implying a 0.775 volt reference voltage level. Thus, a voltage level expressed as +4 dB was calculated by taking 20 times the Log (base 10) of the actual voltage (1.23 volts) divided by the reference voltage (0.775 volts).

The choice of a 0.775 volt reference was not arbitrary. dBm is a common method of rating power levels (as opposed to our voltage level ratings). The 0 dBm reference is one milliwatt (1/1000 watt). If a mixer produces 0 dBm into exactly 600 ohms, the voltage level is 0.775 volts. Thus, for true 600 ohm lines, the dBm power terminology and our dB voltage terminology are equivalent.

The Gain-Level Diagram.

The purpose of this diagram is to express the maximum and nominal voltage levels and the noise floor of each section of the mixer, and to show the gain (or loss) between sections. Once you understand signal flow in the mixer, you can use the GAIN/LEVEL DIAGRAM to help you optimize signal-to-noise ratios and avoid clipping.

Each section of the GAIN/LEVEL DIAGRAM from left to right corresponds to a section of the mixer (sections are shown in the Block Diagrams). The dashed line at the top shows clipping levels in each stage.

Below the clipping line, two lines show the level in each section corresponding to maximum and minimum settings of the Trim control. The lower two lines indicate the noise floor in each section for both line-level and mic-level inputs.

The Connector Normal Charts.

Some of the connectors on your Fender PX-2200 Series Mixer are "normalised" (normally connected) to some other connector in the mixer. When you insert a patch cable into one of the two connectors, you disconnect this "normalised" connection. The chart shows you two things. First it indicates which connectors are "normalised" to which other connectors. Second, by inserting a patch cable into one of the two connectors, you can break the "normalised" connection; the chart tells you which one.

Due to our policy of continual product improvement, features, specifications, and prices are subject to change without notice.

Mixer Section:

Frequency Response: 20 Hz. to 40 KHz. \pm 1 dB

Distortion: <.025%, 20 to 20 KHz. (Mic input to any line level mixer output)

Signal To Noise Ratio: >90 dBu (ref. +4 dBu), all channels assigned and at unity gain.

Microphone Equivalent Input Noise: -133.8 dBv input shorted, -131.5 dBv 150 ohms.

Max. Output Level: +22 dBu (Line Level)

Max. Gain: 84 dB (Mic input to unbalanced main output).

Dynamic Range: 116 dB (20 Hz. to 20 KHz.)

Adjacent Channel Crosstalk: -85 dB

Mic Input Gain: 48 dB

Channel Fader Gain: 10 dB

Channel Fader Attenuation: 106 dB

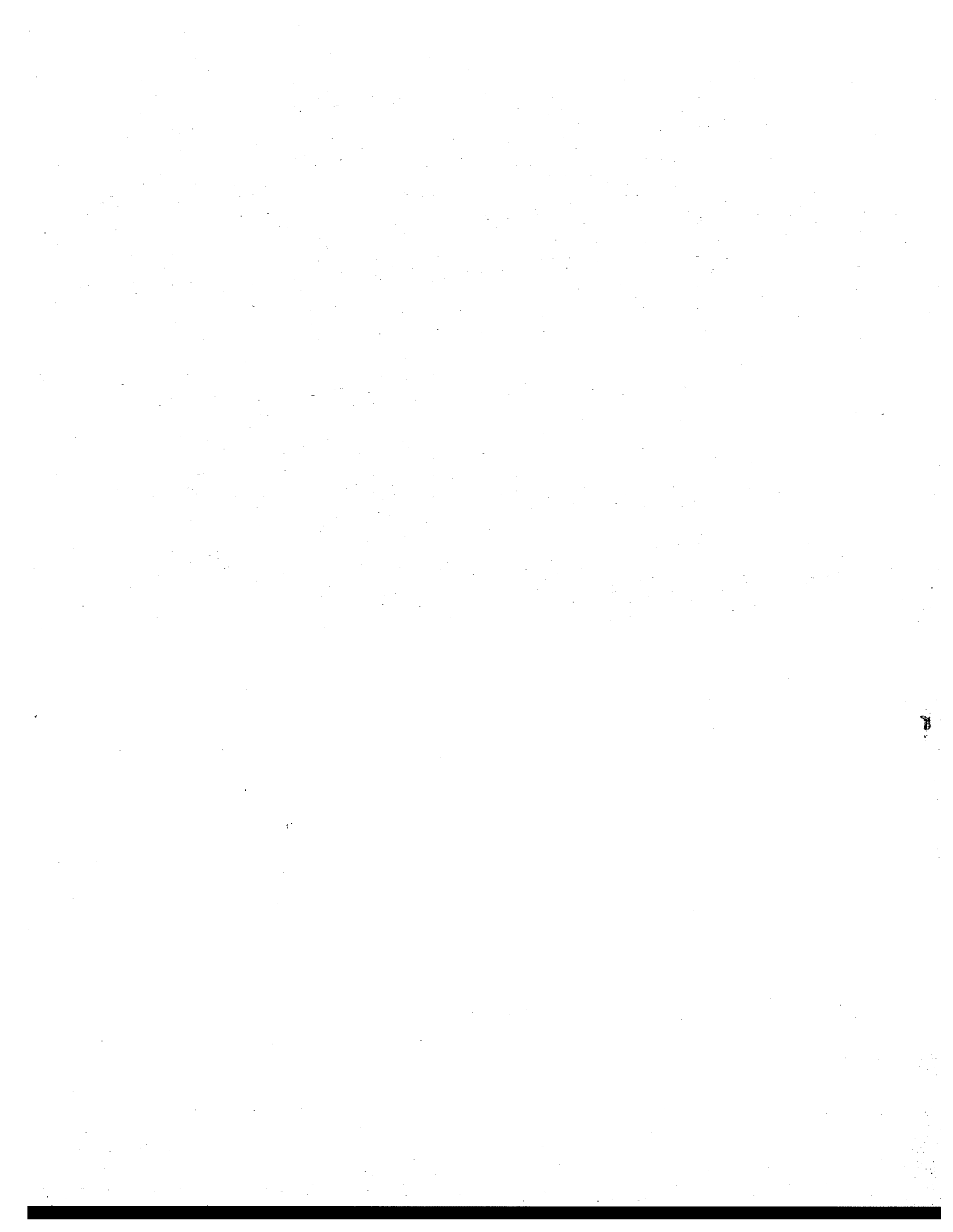

Power Amplifier Section:

Output Power: 150 Watts @ 4 Ohms (PX-2208, PX-2208D)
 300 Watts @ 4 Ohms (PX-2212D, PX-2216D)
 150 Watts @ 8 Ohms, continuous sine wave output power, both channels driven,
 with 120 volt AC line, ± 1 dB

Power Bandwidth: 10 Hz. to 68 KHz. (3 dB down points from rated power at less than .01% THD).

Frequency Response: 5 Hz. to 68 KHz. (+0-3 dB; @ rated power, 8 ohms)

Rise Time: Less than 5.2 uSeconds

Slew Rate: Greater than 13.5 Volts per uSecond

Total Harmonic Distortion: <0.03% @ rated power, 4 Ohms, 20 to 20 KHz.

Hum and Noise: 95 dB below rated output, 4 ohms, 20 Hz. to 20 KHz., broad band, IEC A weighted 102 dB

Damping Factor: Ref. 8 Ohms, 5 Hz. to 20 KHz., >30. @ 1 KHz. >175

Power Amplifier Input Impedance: 33 KOhms

Separation: >65 dB @ 1 KHz.

Sensitivity: 1.8 dBv for rated power @ 1 KHz.

The Connector Normal Charts.

Some of the connectors on your Fender PX-2200 Series Mixer are "normalled" (normally connected) to some other connector in the mixer. When you insert a patch cable into one of the two connectors, you disconnect this "normalled" connection. The chart shows you two things. First it indicates which connectors are "normalled" to which other connectors. Second, by inserting a patch cable into one of the two connectors, you can break the "normalled" connection; the chart tells you which one.

Jack (Connector)	Is Normalled To This Jack	The Normal Is Broken By Patching Into This Jack	Which Disables This Signal
Channel Patch Point	Internally (Access Out to Access In)	Channel Patch Point (allows use as an insert point or Direct Out)	Channel EQ. Out To Channel Fader Input
Graphic EQ. Input (A&B)	Graphic EQ. Assignment Switch Switch	Graphic EQ. Input (A&B)	Feed From Graphic EQ. Assignment Switch
Graphic EQ. Output (A&B)	Amp In (A&B)	Amp In (A&B)	Output of EQ to Power Amp Input
Reverb In	Effects Out	Reverb In	Effects Mix to Reverb Input
Effects Return (L&R)	Rev. Out (L&R)	Effects Ret. (L&R)	Reverb Output To Effects Return In

Portions of this manual were reproduced from previous Fender manuals (3106, 3206, 3208, 3212, 3216, 4200 Series, 2200 Series, 2800 Series, etc.), and from "Making The Connection: The Fender Pro Audio Primer", written by Tom Butler and Pete Horsman. This manual is the sole property of Fender Musical Instruments Corp., and may not be reproduced without written permission. The PX-2200 is a trade mark of FMIC. Delta-Comp is a registered trademark of FMIC.
This manual Copyright FMIC, 1994, all rights reserved.

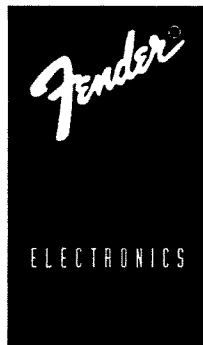

Fender Musical Instruments Corporation

7975 N. Hayden Rd., Scottsdale Az. 85258

Phone: (602) 596-9690

Fax: (602) 596-1384